

HYDRAULIC
GEAR
PUMPS

INDEX

| Section | Description | Page |
|---|--|------|
| FEATURES | | 2 |
| | PERFORMANCE CURVES | 9 |
| SINGLE GEAR PUMPS | FP 20 | 18 |
| | FP 30 | 23 |
| | FP 40 | 31 |
| MULTIPLE GEAR PUMPS | | 37 |
| PORTS CONNECTORS TIGHTENING TORQUE | | 65 |
| SUPPORT | SUPPORT (ISO STANDARD) | 66 |
| | KIT TO ASSEMBLE FORMULA PUMPS WITH SUPPORT | 67 |
| | APPLICATIONS | 68 |
| CHANGING ROTATION | | 70 |
| INSTRUCTIONS | | 71 |

Replaces: 01/08.2005

FEATURES

FORMULA designates a CASAPPA gear pump range specifically designed for applications requiring high pressure levels also at low speed; applications such as truck-mounted cranes, tripper trucks and lift-trucks etc. Special design features and an exclusive CASAPPA patent have perfected a sophisticated mechanism which makes FORMULA a highly reliable unit, proven by years of service in the specific field of use. The versatility offered by the range of Italian (triangular) European (ISO) and American (SAE) mounting flanges allows to the FORMULA pumps to be used in several applications.

DISPLACEMENTS

From 0.50 in³/rev (8,26 cm³/rev)
To 9.20 in³/rev (150,79 cm³/rev)

PRESSURE

Max. continuous 4205 psi (290 bar)
Max. intermittent 4568 psi (315 bar)
Max. di peak 4713 psi (325 bar)

MAX. SPEED

Max. 3000 min⁻¹

- Two piece cast iron housing
- High performance at very low speed
- Ideal for truck applications

| | |
|---|------------------|
| 1 | Mounting flange |
| 2 | Seals |
| 3 | Gear |
| 4 | Body |
| 5 | Thrust plates |
| 6 | Shaft |
| 7 | Outboard bearing |

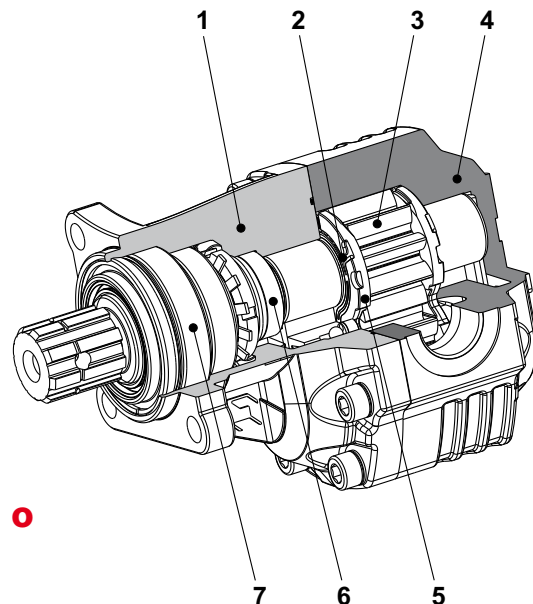

● 03/05.2013



Modification from former edition.

FEATURES

WARNING !

Failure or improper use of the product can cause damage at the same product or system.

Make sure that this is the last issue.

Replaces: 02/07.2008

| | |
|--|--|
| Construction | External gear type pumps |
| Mounting | ISO (ZF), ITALIAN (triangular) and SAE flanges |
| Line connections | Screw |
| Direction of rotation (looking at the drive shaft) | Anti-clock (S) - clockwise (D) - reversible (R or B) |
| Inlet pressure range for pumps | 10 ÷ 44 psi - [0,7 ÷ +3 bar (abs.)] |
| Fluid temperature range | See table (1) |
| Fluid | Mineral oil based hydraulic fluids to ISO/DIN and fire resistant fluids [see table (1)]. For other fluids please consult our technical sales department. |
| Viscosity range | From 60 to 456 SSU [12 to 100 mm ² /s (cSt)] recommended Up to 3410 SSU [750 mm ² /s (cSt)] permitted |
| Filtering requirement | See table (2) |
| Antioxidant protection | Red paint IC105 |

Tab. 1

| Type | Fluid composition | Max pressure psi - (bar) | Max speed min ⁻¹ | Temperature °F - (°C) | | | Seals (◆) |
|---------|--|-----------------------------|--------------------------------|-----------------------|----------------|-----------|--------------|
| | | | | Min | Max continuous | Max peak | |
| ISO/DIN | Mineral oil based hydraulic fluid to ISO/DIN | See page 5 - 6 - 7 | See page 5 - 6 - 7 | -13 (-25) | 176 (80) | 212 (100) | N |
| | | | | -13 (-25) | 230 (110) | 257 (125) | V |
| HFA | Oil emulsion in water 5 ÷ 15% of oil | 725 (50) | 1500 | 36 (2) | 131 (55) | – | N |
| HFB | Water emulsion in oil 40 % of water | 1740 (120) | 1500 | 36 (2) | 140 (60) | – | N |
| HFC | Water - glycol | 1450 (100) | 1500 | -4 (-20) | 140 (60) | – | N Bz |
| HFD | Phosphate ester (●) | 2175 (150) | 1500 | 14 (-10) | 176 (80) | – | V Bz |

(◆) **N** = Buna N (standard) - **V** = Viton - **N Bz** = Buna N and Bronze thrust plates - **V Bz** = Viton and Bronze thrust plates.

(●) For skydrol phosphate esters please consult our technical sales department.

03/05.2013

Tab. 2

| Working pressure psi (bar) | $\Delta p < 2030$ (140) | $2030 < \Delta p < 3045$ (140) (210) | $\Delta p > 3045$ (210) |
|--|----------------------------|---|----------------------------|
| Contamination class NAS 1638 | 10 | 9 | 8 |
| Contamination class ISO 4406:1999 | 21/19/16 | 20/18/15 | 19/17/14 |
| Achieved with filter $\beta_{10(c)} \geq 200$ according to ISO 16889 | – | 10 μ m | 10 μ m |
| Achieved with filter $\beta_{25(c)} \geq 200$ according to ISO 16889 | 25 μ m | – | – |

Casappa recommends to use its own production filters:



FEATURES

DEFINITION OF ROTATION DIRECTION LOOKING AT THE DRIVE SHAFT

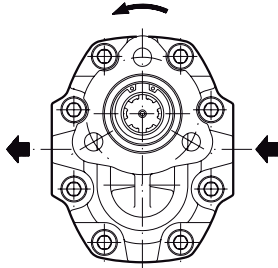

ANT-CLOCK ROTATION

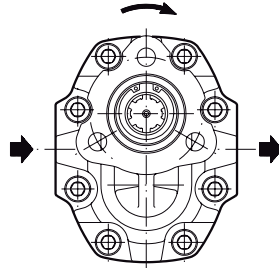

CLOCKWISE ROTATION

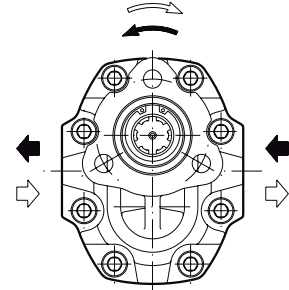

REVERSIBLE ROTATION

PRESSURE DEFINITION

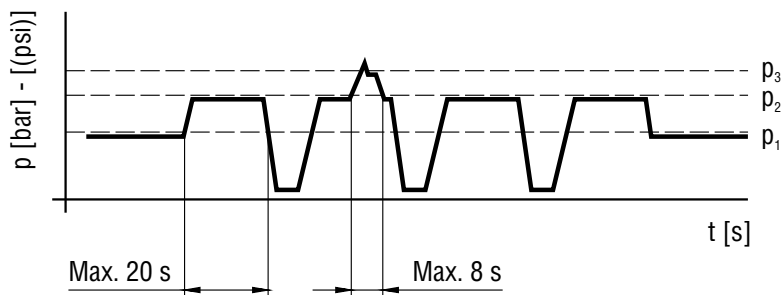

p_1 Max. continuous pressure
 p_2 Max. intermittent pressure
 p_3 Max. peak pressure

GENERAL NOTES

Available with different inlet and outlet ports. Standard pumps are equipped with BUNA N (N) seals, for particular operating conditions (V) VITON seals and BUNA or VITON seals with bronze thrust plates (N Bz), (V Bz) are available. If you use fire resistant fluids specify the type of them at the order. For more information please consult our technical sales department.

01/08.2005

FORMULA 20 GENERAL DATA PUMPS
FP 20

| Pump type | Displacement in ³ /rev (cm ³ /rev) | Max. pressure | | | Intermittent max. speed | | Min. speed |
|-----------------------|---|----------------|----------------|----------------|--------------------------|--------------|--------------------------|
| | | p ₁ | p ₂ | p ₃ | At p ₂ press. | Without load | At p ₂ press. |
| | | psi (bar) | | | min ⁻¹ | | |
| FP 20•8 (•) | 0.50 (8,26) | 4060 (280) | 4495 (310) | 4713 (325) | 2000 | 4200 | 300 |
| FP 20•11,2 (•) | 0.69 (11,23) | 4060 (280) | 4495 (310) | 4713 (325) | 2000 | 4200 | 300 |
| FP 20•16 | 1.03 (16,85) | 4060 (280) | 4495 (310) | 4713 (325) | 2000 | 4200 | 300 |
| FP 20•20 | 1.29 (21,14) | 3770 (260) | 4060 (280) | 4205 (290) | 2000 | 4200 | 300 |
| FP 20•25 | 1.61 (26,42) | 3190 (220) | 3625 (250) | 3770 (260) | 2000 | 4200 | 300 |
| FP 20•31,5 | 2.01 (33,03) | 2755 (190) | 3045 (210) | 3190 (220) | 1800 | 4000 | 300 |
| FP 20•36 (•) | 2.19 (35,94) | 2465 (170) | 2755 (190) | 2900 (200) | 1800 | 4000 | 300 |
| FP 20•40 | 2.42 (39,64) | 2320 (160) | 2610 (180) | 2755 (190) | 1800 | 4000 | 300 |

(•) Only available in ISO 16 Z0 and ITALIAN 13 T1 version.

p₁= Max. continuous pressure

p₂= Max. intermittent pressure

p₃= Max. peak pressure

The values in the table refer to unidirectional and reversible pumps.

01/08.2005

FORMULA 30 GENERAL DATA PUMPS

FP 30

| Pump type | Displacement | Max. pressure | | | Intermittent max. speed | | Min. speed |
|------------------|---|---------------|------------|------------|-------------------------|--------------|-----------------|
| | | p_1 | p_2 | p_3 | At p_2 press. | Without load | At p_2 press. |
| | in ³ /rev (cm ³ /rev) | psi (bar) | | | min ⁻¹ | | |
| FP 30•17 | 1.05 (17,28) | 4205 (290) | 4568 (315) | 4713 (325) | 3000 | 4000 | 300 |
| FP 30•27 | 1.63 (26,70) | 4205 (290) | 4568 (315) | 4713 (325) | 3000 | 4000 | 300 |
| FP 30•34 | 2.11 (34,56) | 4060 (280) | 4350 (300) | 4495 (310) | 2800 | 4200 | 300 |
| FP 30•38 | 2.40 (39,27) | 4060 (280) | 4350 (300) | 4495 (310) | 2800 | 3500 | 300 |
| FP 30•43 | 2.68 (43,98) | 3915 (270) | 4205 (290) | 4350 (300) | 2500 | 3500 | 300 |
| FP 30•51 | 3.16 (51,83) | 3480 (240) | 3770 (260) | 4060 (280) | 2500 | 3500 | 300 |
| FP 30•61 | 3.74 (61,26) | 3190 (220) | 3480 (240) | 3625 (250) | 2000 | 3500 | 300 |
| FP 30•73 | 4.50 (73,82) | 2900 (200) | 3190 (220) | 3335 (230) | 1800 | 3500 | 300 |
| FP 30•82 | 4.98 (81,68) | 2755 (190) | 3045 (210) | 3190 (220) | 1800 | 3500 | 300 |
| FP 30•100 | 6.16 (100,52) | 2610 (180) | 2900 (200) | 3190 (220) | 1800 | 3500 | 300 |
| FP 30•125 | 7.67 (125,66) | 2320 (160) | 2610 (180) | 2900 (200) | 1800 | 3500 | 300 |

p_1 = Max. continuous pressure

p_2 = Max. intermittent pressure

p_3 = Max. peak pressure

The values in the table refer to unidirectional pumps.
 Reversible pump max pressures are 15% lower than those shown in table.
 For different working conditions please consult our sales department.

T2 type double shaft flange allow the pumps to work in clockwise or anticlockwise rotation obtaining the reversible advantages and maintaining the general data of unidirectional pumps.

01/08.2005

FORMULA 40 GENERAL DATA PUMPS
FP 40

| Pump type | Displacement in ³ /rev (cm ³ /rev) | Max. pressure | | | Intermittent max. speed | | Min. speed |
|------------------|---|----------------|----------------|----------------|--------------------------|--------------|--------------------------|
| | | p ₁ | p ₂ | p ₃ | At p ₂ press. | Without load | At p ₂ press. |
| | | psi (bar) | | | min ⁻¹ | | |
| FP 40•63 | 3.75 (61,43) | 4205 (290) | 4568 (315) | 4713 (325) | 2700 | 4200 | 300 |
| FP 40•73 | 4.43 (72,60) | 4060 (280) | 4350 (300) | 4568 (315) | 2700 | 4200 | 300 |
| FP 40•87 | 5.28 (86,56) | 3770 (260) | 4060 (280) | 4205 (290) | 2700 | 4000 | 300 |
| FP 40•109 | 6.64 (108,90) | 3480 (240) | 3770 (260) | 4060 (280) | 2700 | 4000 | 300 |
| FP 40•133 | 8.18 (134,03) | 3190 (220) | 3625 (250) | 3770 (260) | 2500 | 4000 | 300 |
| FP 40•151 | 9.20 (150,79) | 2610 (180) | 3045 (210) | 3190 (220) | 2500 | 4000 | 300 |

p₁= Max. continuous pressure

p₂= Max. intermittent pressure

p₃= Max. peak pressure

The values in the table refer to unidirectional pumps.
 Reversible pump max pressures are 15% lower than those shown in table.
 For different working conditions please consult our sales department.

T2 type double shaft flange allow the pumps to work in clockwise or anticlockwise rotation obtaining the reversible advantages and maintaining the general data of unidirectional pumps.

01/08.2005

DESIGN CALCULATIONS FOR PUMPS

| | | |
|--|---|-----------------------|
| Q | US gpm (l/min) | Flow |
| M | lbf in(Nm) | Torque |
| P | HP (kW) | Power |
| V | in ³ /rev (cm ³ /rev) | Displacement |
| n | min ⁻¹ | Speed |
| Δp | psi (bar) | Pressure |
| $\eta_v = \eta_v (V, \Delta p, n)$ | ($\approx 0,98$) | Volumetric efficiency |
| $\eta_{hm} = \eta_{hm} (V, \Delta p, n)$ | ($\approx 0,90$) | Mechanical efficiency |
| $\eta_t = \eta_v \cdot \eta_{hm}$ | ($\approx 0,88$) | Overall efficiency |

Replaces: 01/08.2005

$$\begin{aligned}
 \bullet \quad Q &= Q_{\text{theor.}} \cdot \eta_v \\
 Q_{\text{theor.}} &= \frac{V \text{ (cm}^3\text{/rev)} \cdot n \text{ (min}^{-1}\text{)}}{1000} \quad [\text{l/min}] \\
 M &= \frac{M_{\text{theor.}}}{\eta_{hm}} \quad [\text{Nm}] \\
 M_{\text{theor.}} &= \frac{\Delta p \text{ (bar)} \cdot V \text{ (cm}^3\text{/rev)}}{62,83} \\
 P_{\text{IN}} &= \frac{P_{\text{OUT}}}{\eta_t} \quad [\text{kW}] \\
 P_{\text{OUT}} &= \frac{\Delta p \text{ (bar)} \cdot Q \text{ (l/min)}}{600}
 \end{aligned}$$

03/05.2013

Note: Diagrams providing approximate selection data will be found on subsequent pages.

FORMULA 20 GEAR PUMPS PERFORMANCE CURVES

FP 20

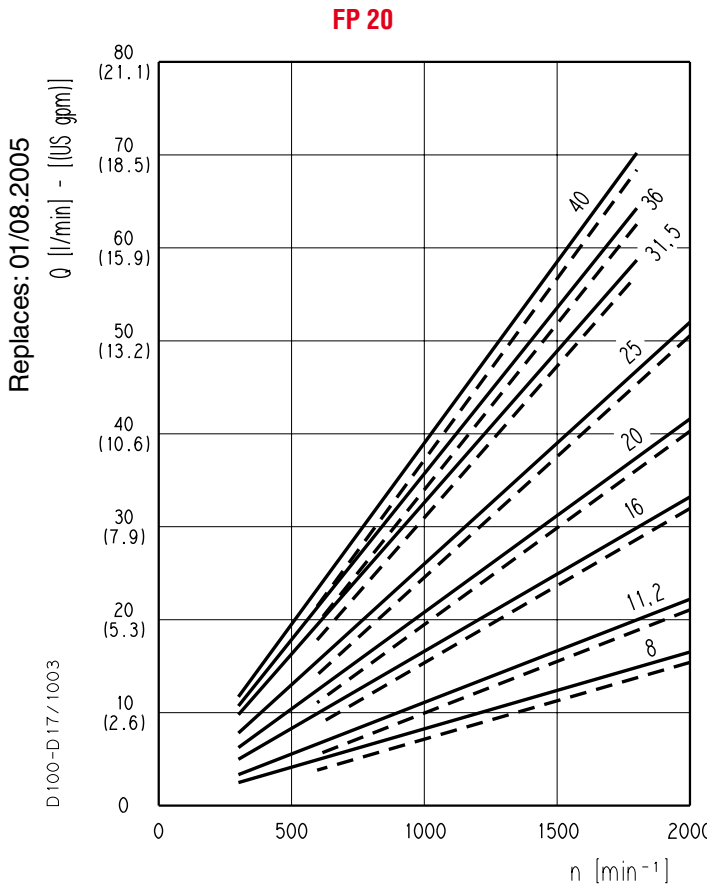

Each curve has been obtained at 122 °F (50°C), using oil with viscosity 168 SSU (36 cSt) at 104 °F (40°C) and at these pressures:

| | | |
|---------------------|-----|--------------------|
| ○ FP 20•8 | --- | 290 psi (20 bar) |
| | — | 4060 psi (280 bar) |
| ○ FP 20•11,2 | --- | 290psi (20 bar) |
| | — | 4060 psi (280 bar) |
| ○ FP 20•16 | --- | 290 psi (20 bar) |
| | — | 4060 psi (280 bar) |
| ○ FP 20•20 | --- | 290 psi (20 bar) |
| | — | 3770 psi (260 bar) |
| ○ FP 20•25 | --- | 290 psi (20 bar) |
| | — | 3190 psi (220 bar) |
| ○ FP 20•31,5 | --- | 290 psi (20 bar) |
| | — | 2755 psi (190 bar) |
| ○ FP 20•36 | --- | 290 psi (20 bar) |
| | — | 2465 psi (170 bar) |
| ○ FP 20•40 | --- | 290 psi (20 bar) |
| | — | 2320 psi (160 bar) |

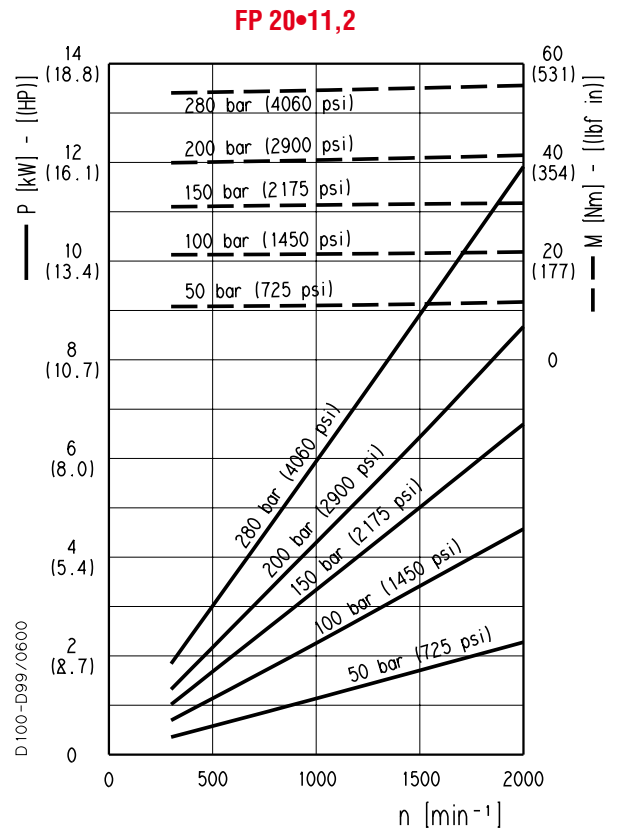
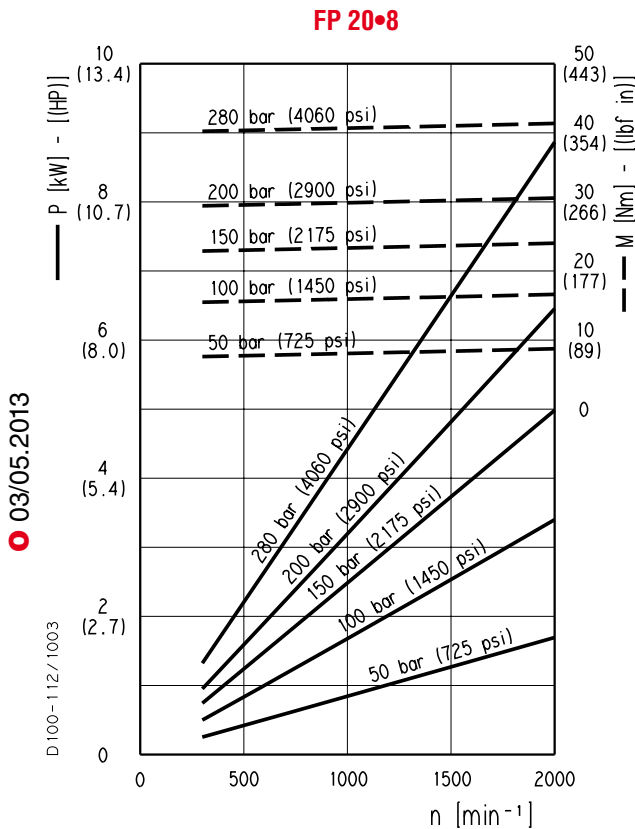

03/05.2013

FORMULA 20 GEAR PUMPS PERFORMANCE CURVES

FP 20

FP 20•16

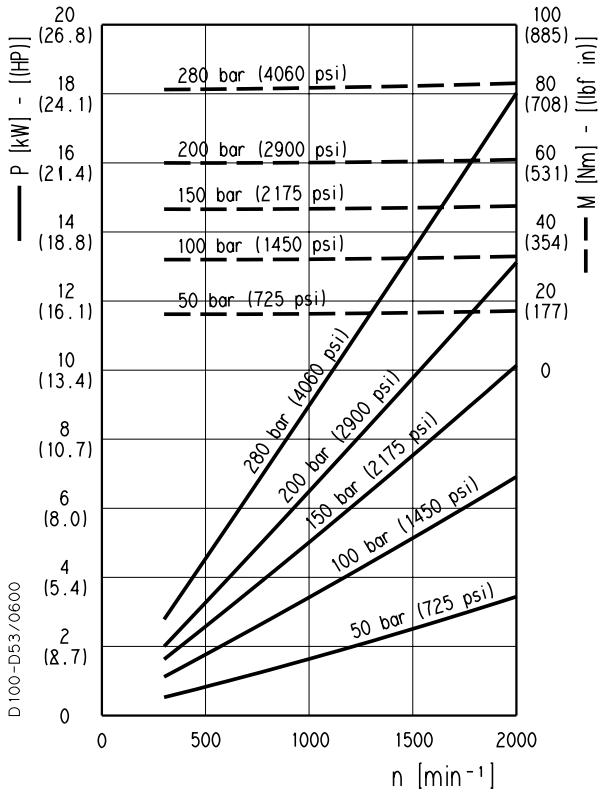

FP 20•20

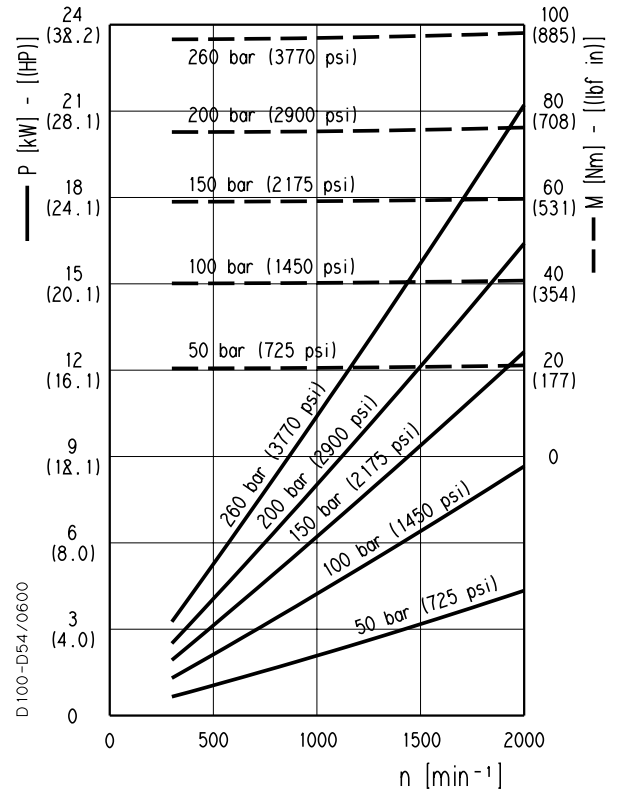

FP 20•25

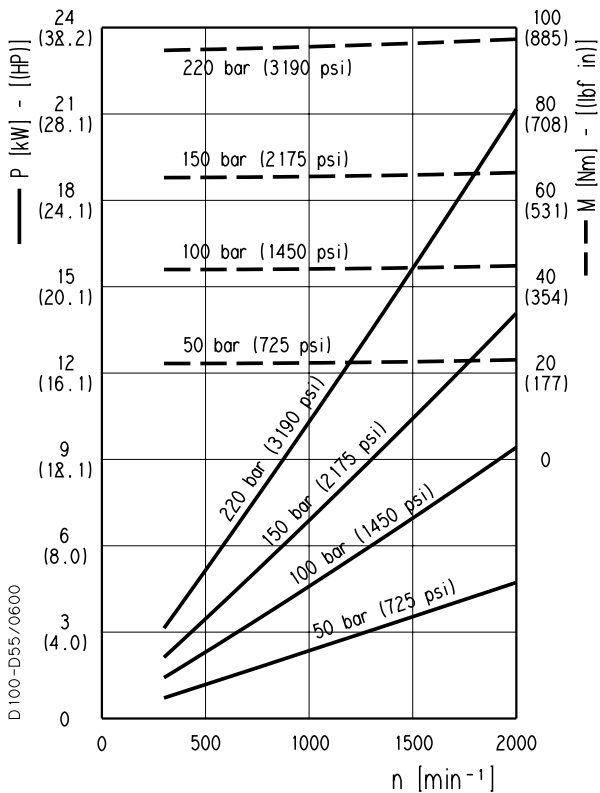

FP 20•31,5

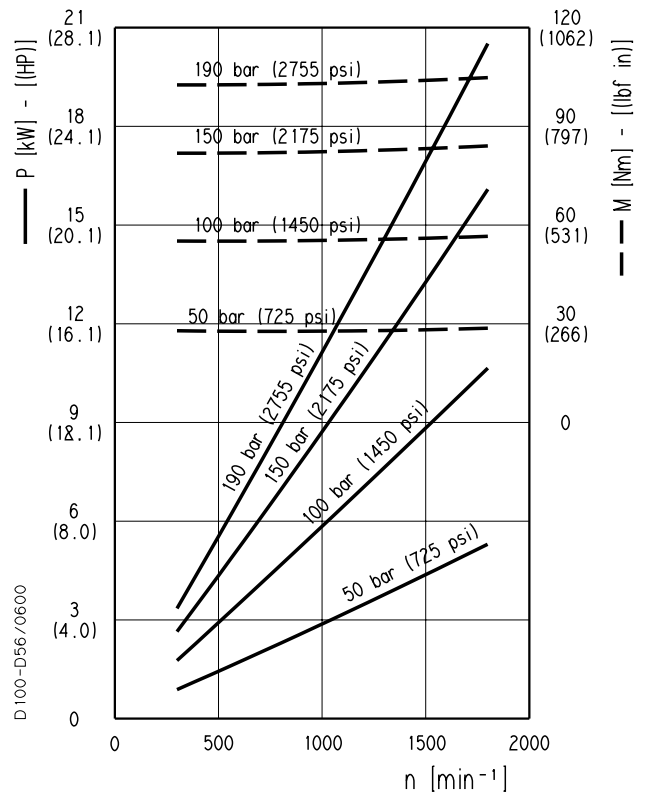

01/08.2005

FORMULA 20 GEAR PUMPS PERFORMANCE CURVES

FP 20

FP 20•36

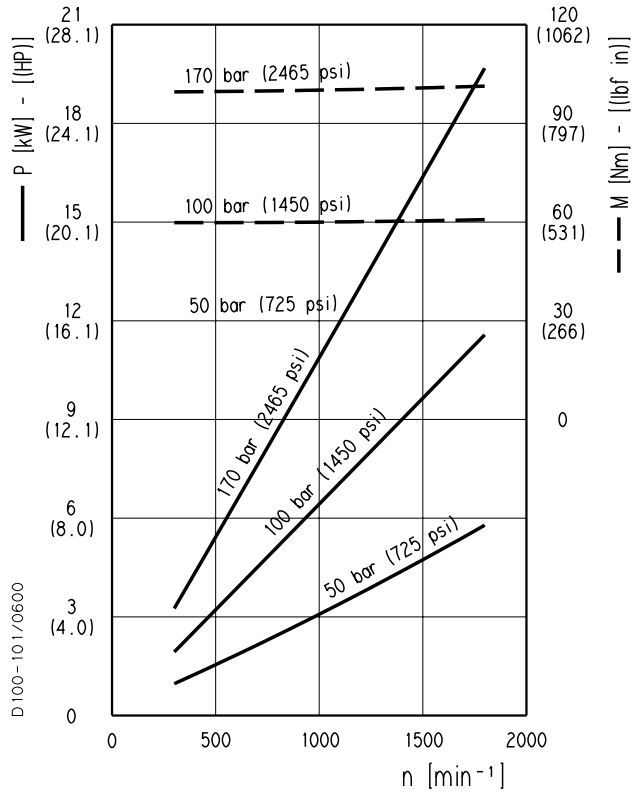

FP 20•40

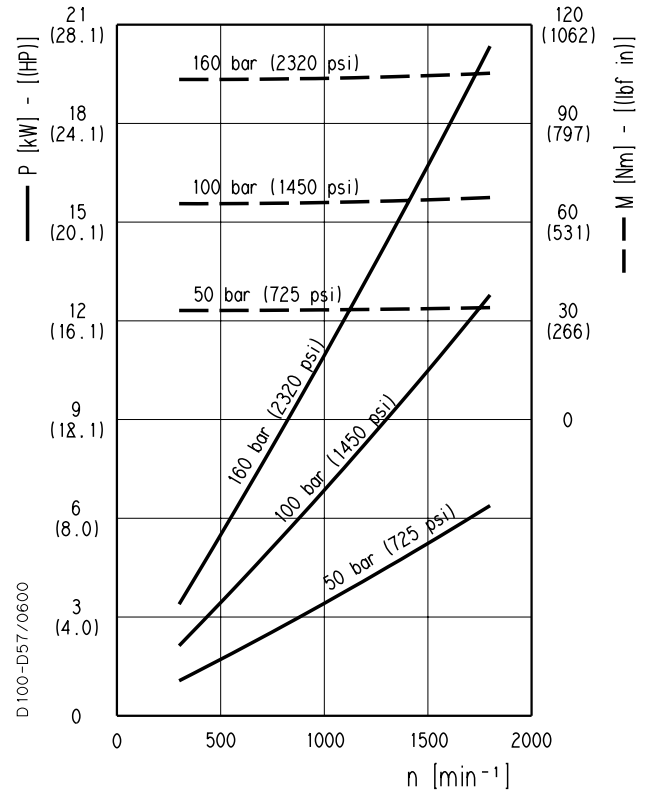

01/08.2005

FORMULA 30 GEAR PUMPS PERFORMANCE CURVES

FP 30

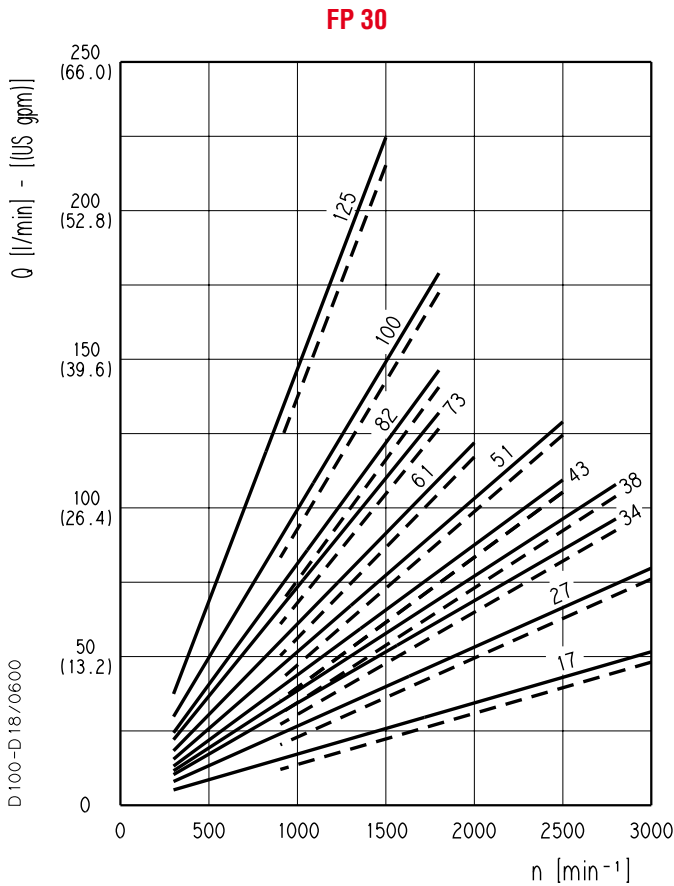

Each curve has been obtained at 122 °F (50°C), using oil with viscosity 168 SSU (36 cSt) at 104 °F (40°C) and at these pressures:

| | | | |
|---|------------------|-----|--------------------|
| ○ | FP 30•17 | — | 290 psi (20 bar) |
| | | - - | 4205 psi (290 bar) |
| | FP 30•27 | — | 290 psi (20 bar) |
| | | - - | 4205 psi (290 bar) |
| | FP 30•34 | — | 290 psi (20 bar) |
| | | - - | 4060 psi (280 bar) |
| | FP 30•38 | — | 290 psi (20 bar) |
| | | - - | 4060 psi (280 bar) |
| | FP 30•43 | — | 290 psi (20 bar) |
| | | - - | 3915 psi (270 bar) |
| | FP 30•51 | — | 290 psi (20 bar) |
| | | - - | 3480 psi (240 bar) |
| | FP 30•61 | — | 290 psi (20 bar) |
| | | - - | 3190 psi (220 bar) |
| | FP 30•73 | — | 290 psi (20 bar) |
| | | - - | 2900 psi (200 bar) |
| | FP 30•82 | — | 290 psi (20 bar) |
| | | - - | 2755 psi (190 bar) |
| | FP 30•100 | — | 290 psi (20 bar) |
| | | - - | 2610 psi (180 bar) |
| | FP 30•125 | — | 290 psi (20 bar) |
| | | - - | 2320 psi (160 bar) |

Replaces: 01/08.2005

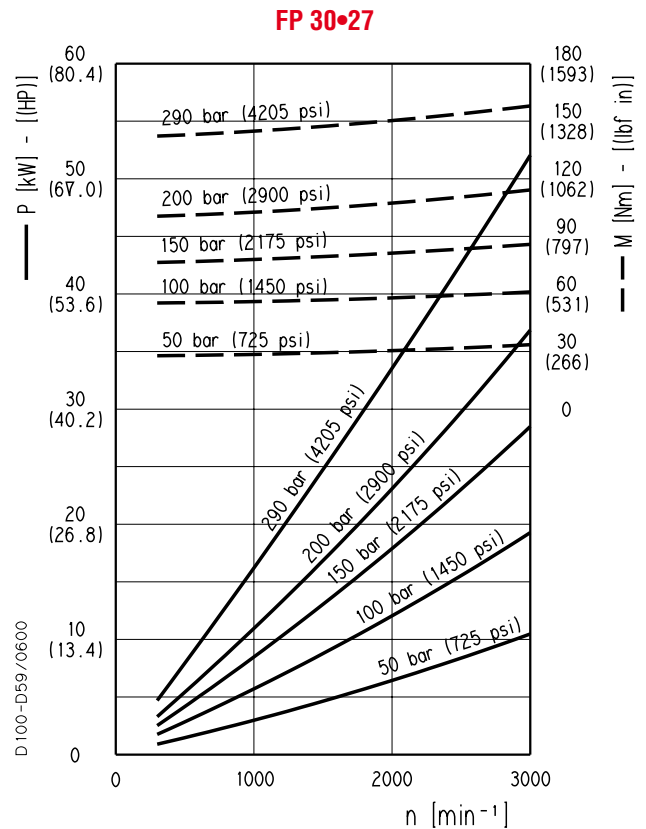
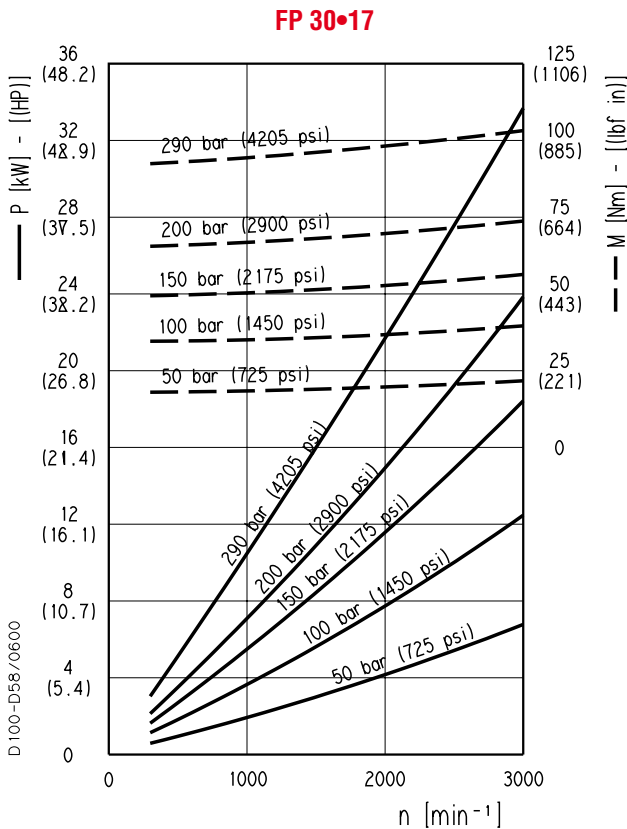

○ 03/05.2013

FORMULA 30 GEAR PUMPS PERFORMANCE CURVES

FP 30

FP 30•34

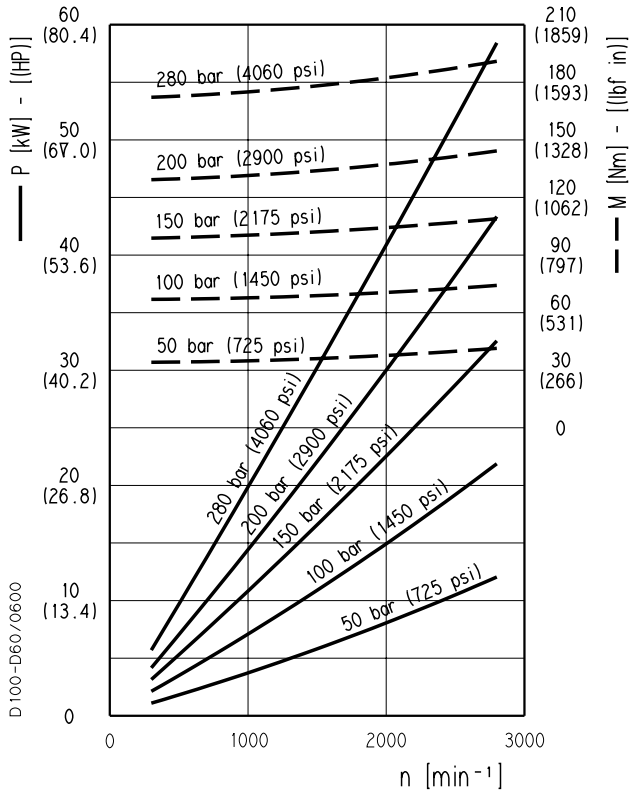

FP 30•38

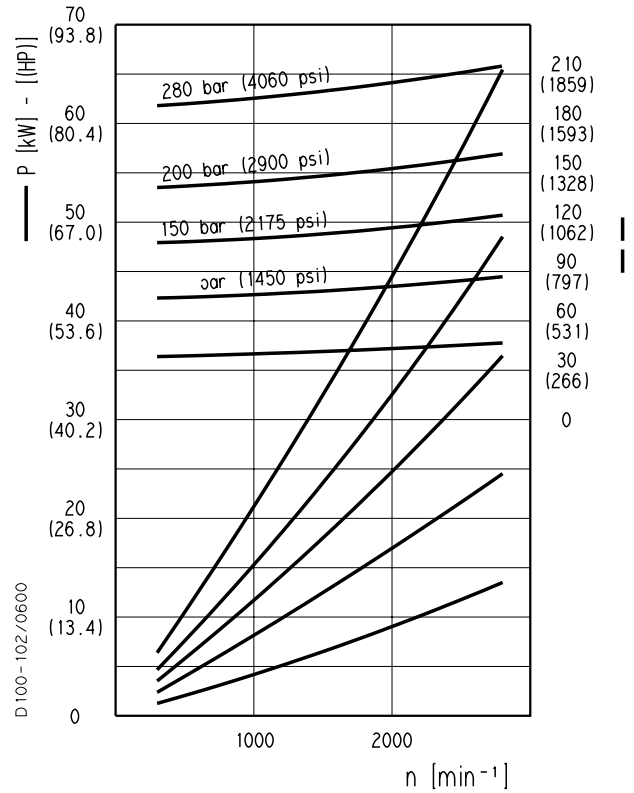

FP 30•43

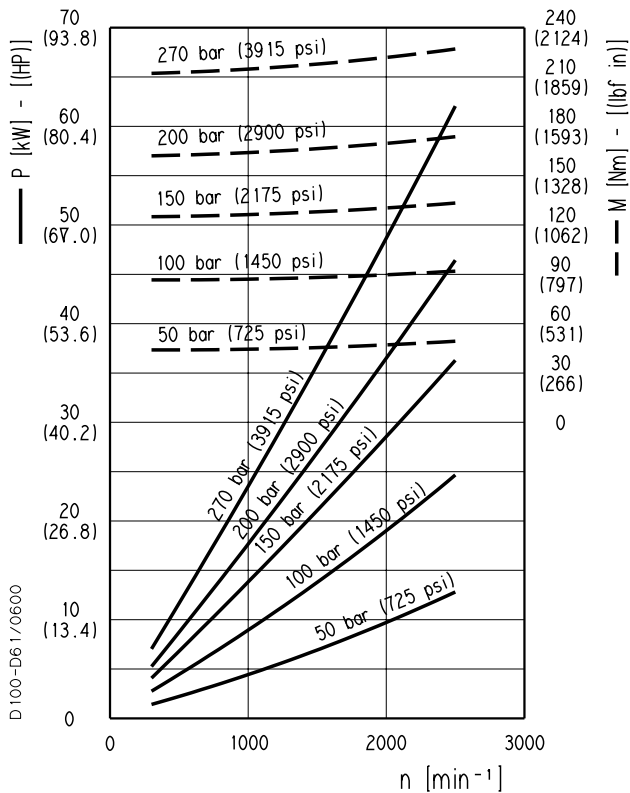

FP 30•51

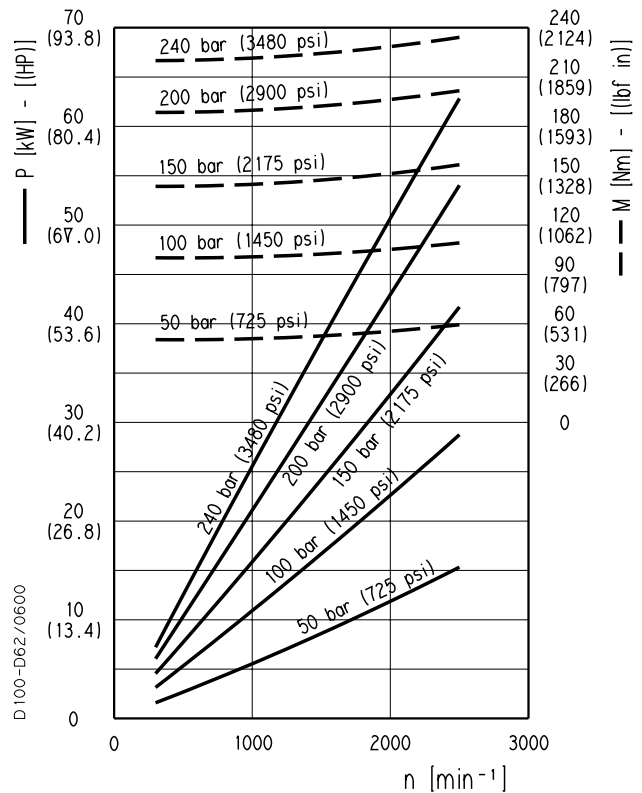

01/08.2005

FORMULA 30 GEAR PUMPS PERFORMANCE CURVES

FP 30

FP 30•61

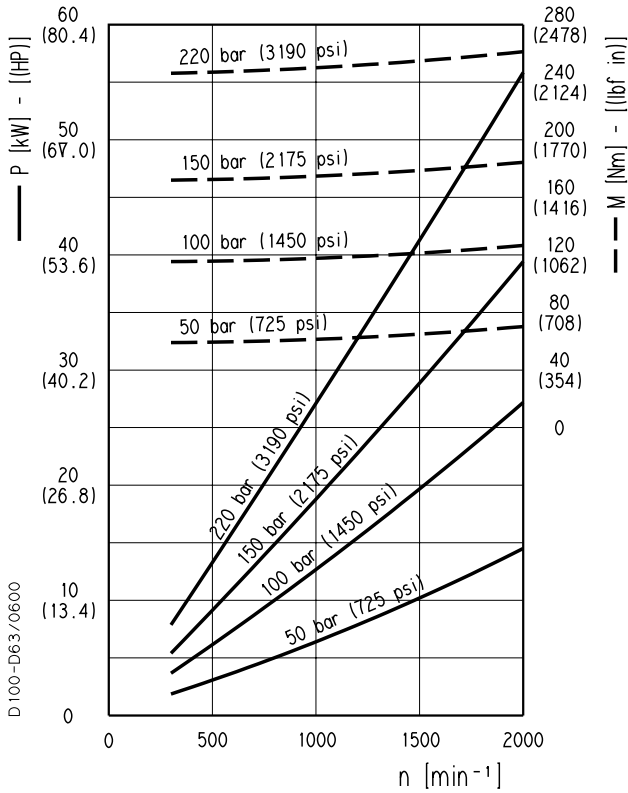

FP 30•73

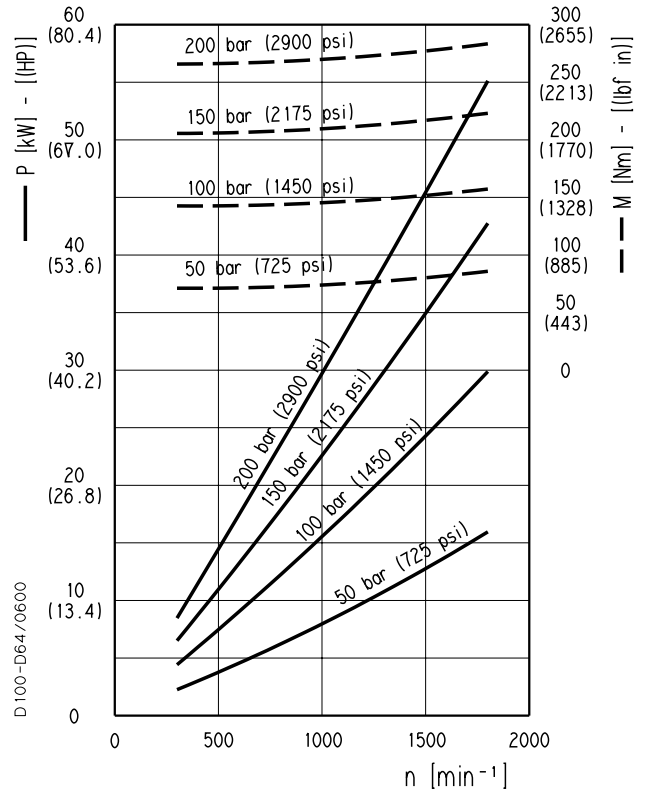

FP 30•82

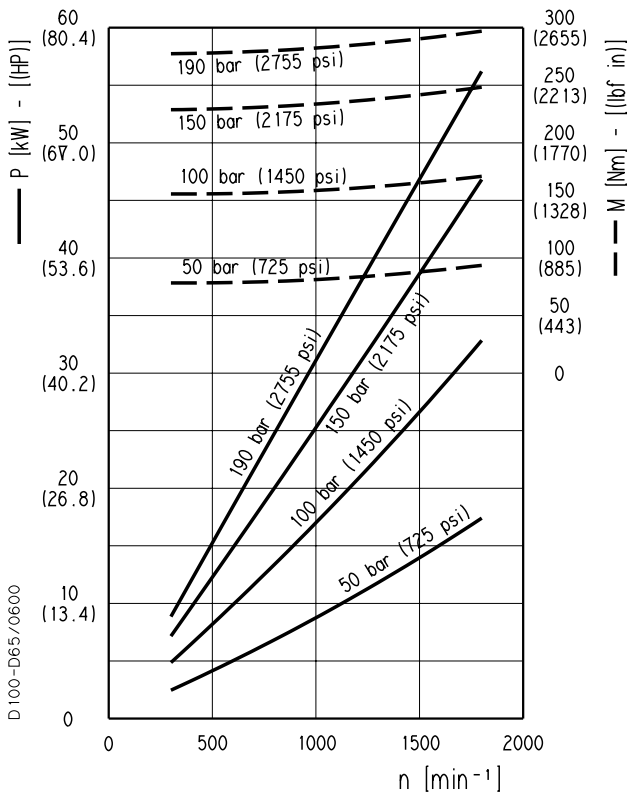

FP 30•100

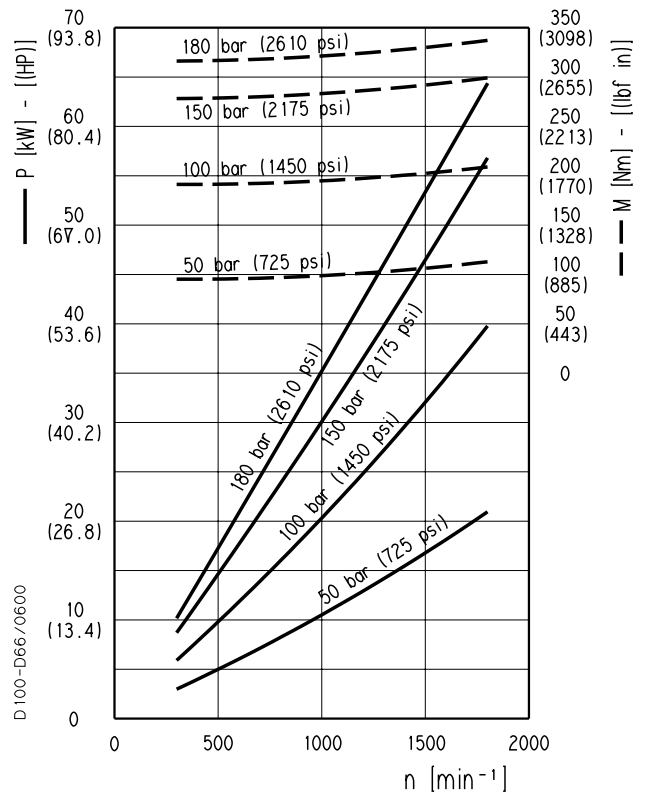

01/08.2005

FORMULA 30 GEAR PUMPS PERFORMANCE CURVES

FP 30

FP 30•125

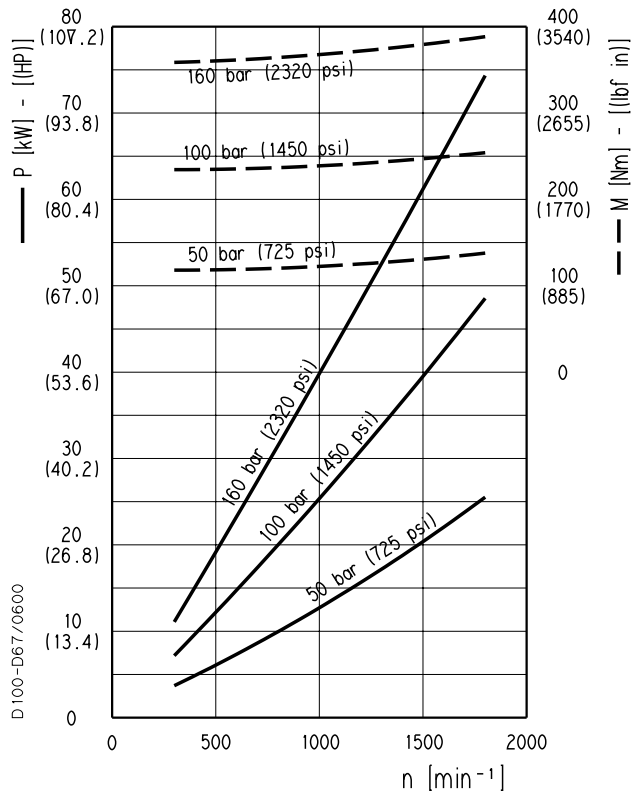

01/08.2005

FORMULA 40 GEAR PUMPS PERFORMANCE CURVES

FP 40

FP 40

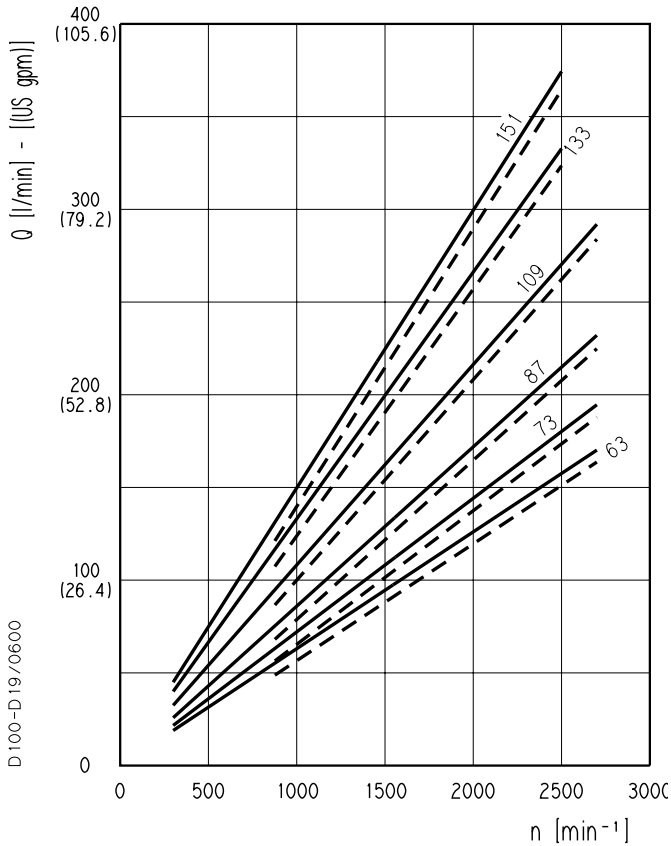

Each curve has been obtained at 122 °F (50°C), using oil with viscosity 168 SSU (36 cSt) at 104 °F (40°C) and at these pressures:

| | | | |
|---|------------------|-----|--------------------|
| ○ | FP 40•63 | — | 290 psi (20 bar) |
| | | - - | 4205 psi (290 bar) |
| ○ | FP 40•73 | — | 290 psi (20 bar) |
| | | - - | 4060 psi (280 bar) |
| ○ | FP 40•87 | — | 290 psi (20 bar) |
| | | - - | 3770 psi (260 bar) |
| ○ | FP 40•109 | — | 290 psi (20 bar) |
| | | - - | 3480 psi (240 bar) |
| ○ | FP 40•133 | — | 290 psi (20 bar) |
| | | - - | 3190 psi (220 bar) |
| ○ | FP 40•151 | — | 290 psi (20 bar) |
| | | - - | 2610 psi (180 bar) |

Replaces: 01/08.2005

FP 40•63

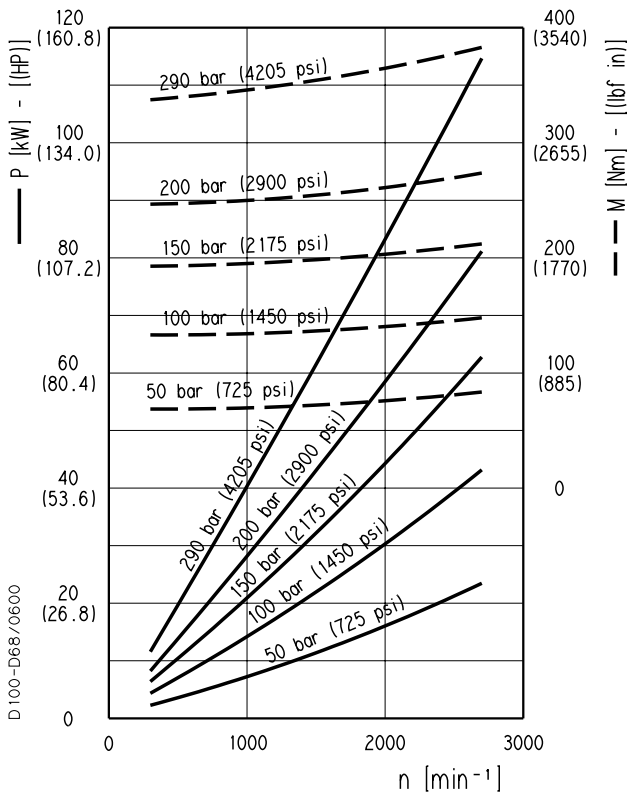

FP 40•73

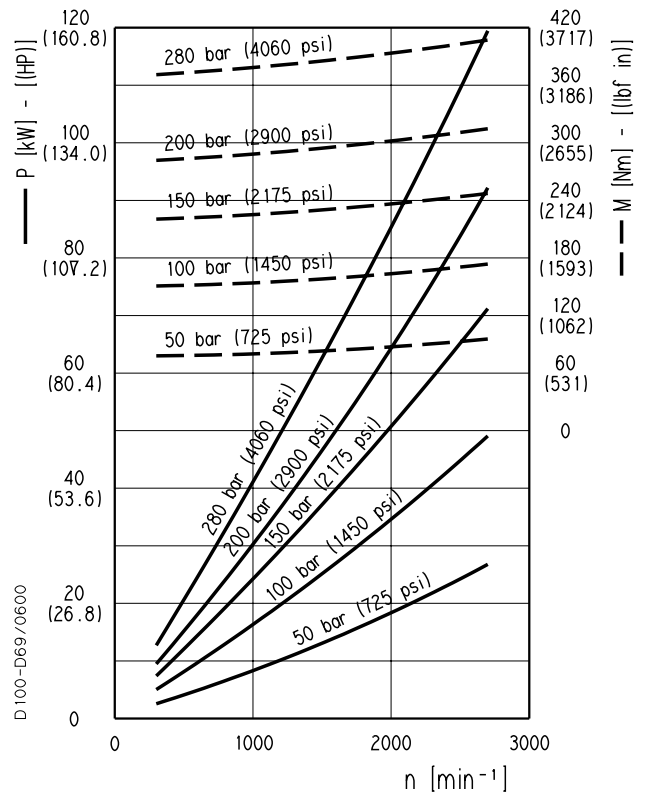

○ 03/05.2013

FORMULA 40 GEAR PUMPS PERFORMANCE CURVES

FP 40

FP 40•87

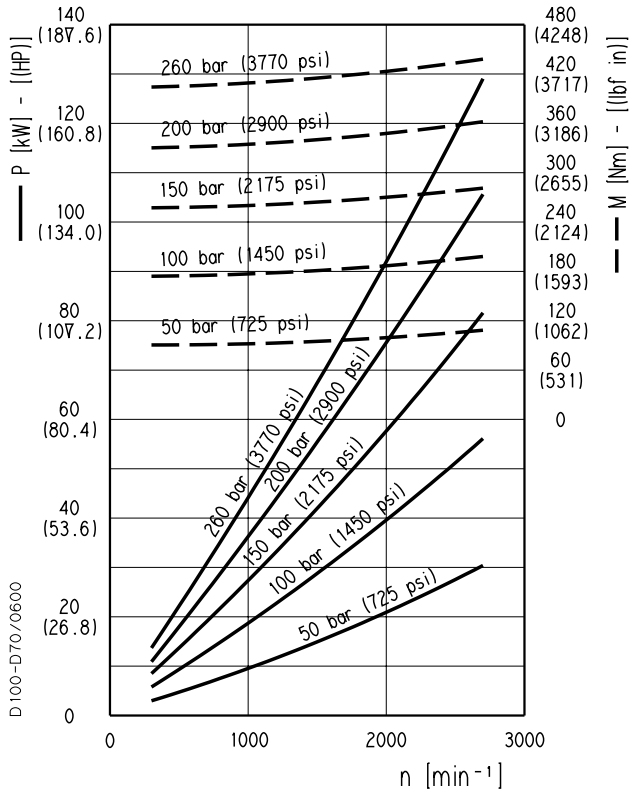

FP 40•109

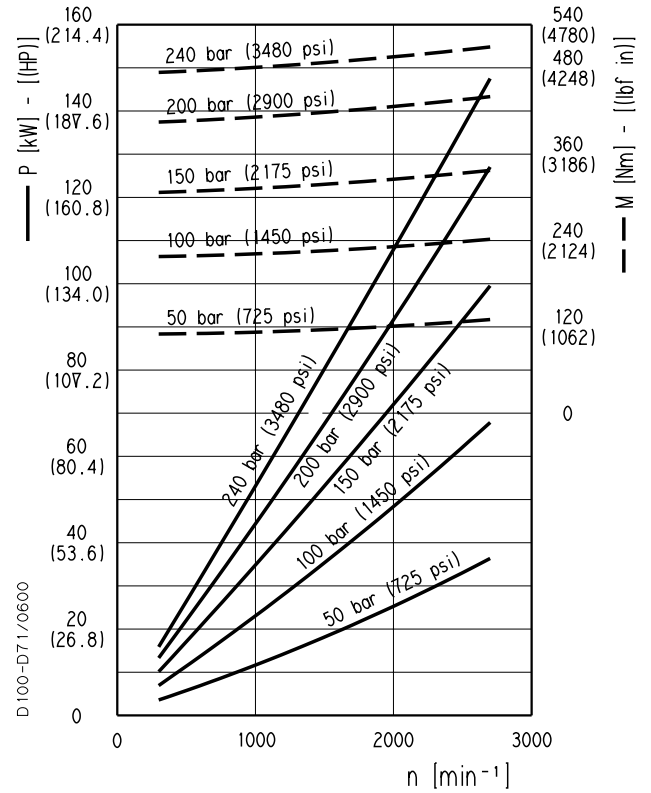

FP 40•133

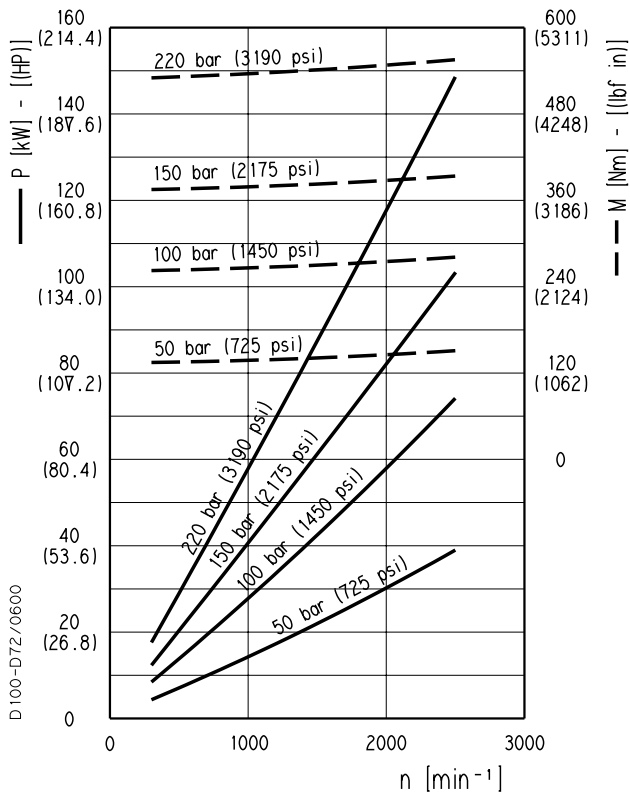

FP 40•151

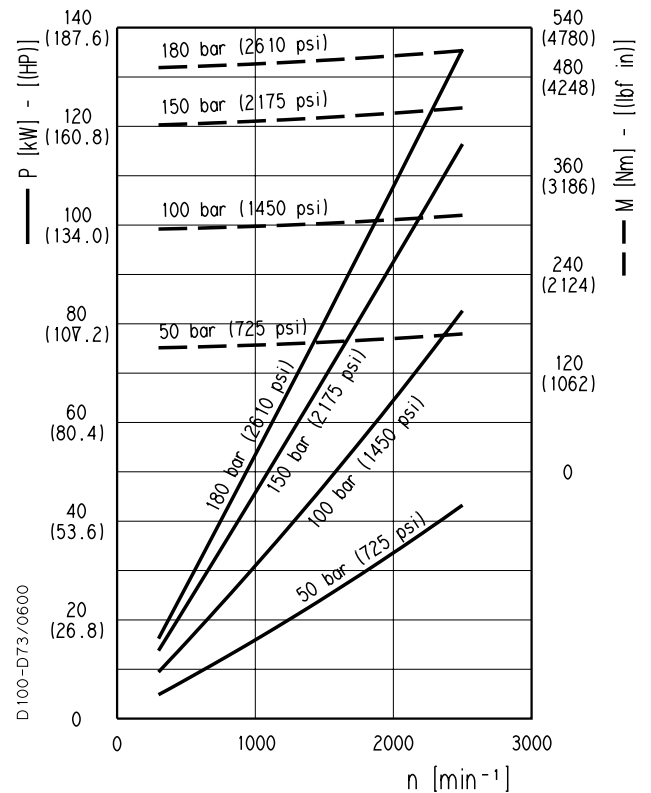

01/08.2005

GAS STRAIGHT THREAD PORTS
British standard pipe parallel (55°) conforms to UNI - ISO 228

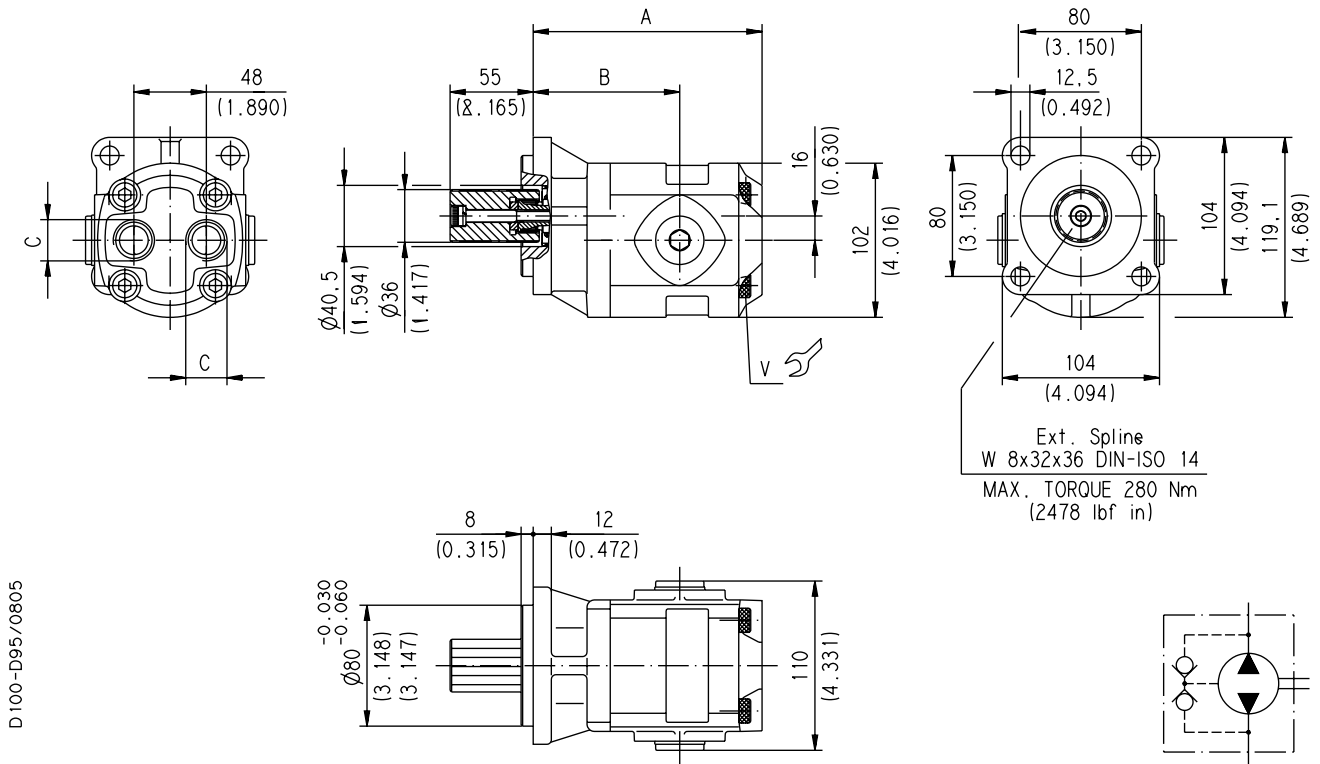

D 100-D95/0805

Radial and/or axial load are not allowed.

Standard version pumps have reversible rotation and internal drain.

The drawing shows the version with rear ports.

Removing the lateral plugs all possible combination ports are allowed.

Screw tightening torque Nm (lbf in)

V

70 ±7 (558 ÷ 682)

| Pump type | A | B | C | Mass |
|-------------------|---------------|--------------|-------|--------------|
| | mm (in) | mm (in) | | kg (lbs) |
| FP 20•8 | 104 (4.094) | 80 (3.150) | G 1/2 | 5,31 (11.71) |
| FP 20•11,2 | 107,5 (4.232) | 83,5 (3.287) | | 5,70 (12.57) |
| FP 20•16 | 117 (4.606) | 87,5 (3.445) | | 6,00 (13.23) |
| FP 20•20 | 123,5 (4.862) | 94 (3.701) | | 6,35 (14.00) |
| FP 20•25 | 131,5 (5.177) | 87 (3.425) | G 3/4 | 6,80 (14.99) |
| FP 20•31,5 | 141,5 (5.571) | 97 (3.819) | | 7,18 (15.83) |
| FP 20•36 | 146,4 (5.764) | 91,4 (3.598) | | 7,44 (16.41) |
| FP 20•40 | 151,5 (5.965) | 97 (3.819) | | 7,80 (17.20) |

How to order:

FP 20•8 B0-16Z0-(L)P GD/GD-N

01/08.2005

GAS STRAIGHT THREAD PORTS

British standard pipe parallel (55°) conforms to UNI - ISO 228

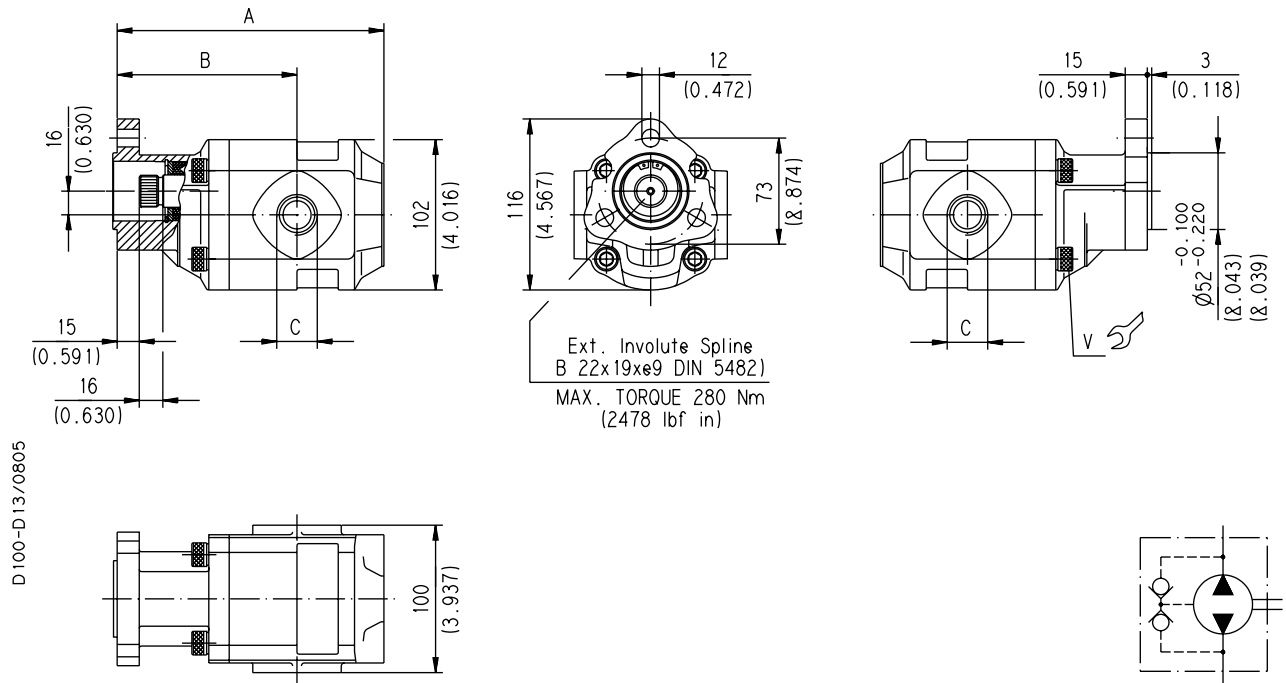

Standard version pumps have reversible rotation and internal drain.

Screw tightening torque Nm (lbf in)

| |
|-------------------|
| V |
| 70 ±7 (558 ÷ 682) |

01/08.2005

| Pump type | A | B | C | Mass |
|-------------------|---------------|---------------|----------|-------------|
| | mm (in) | mm (in) | | kg (lbs) |
| FP 20•8 | 132,5 (5.217) | 105 (4.134) | G 1/2 | 4,8 (10.58) |
| FP 20•11,2 | 136 (5.354) | 108,5 (4.272) | | 5 (11.03) |
| FP 20•16 | 145,5 (5.728) | 112,5 (4.429) | | 5,2 (11.47) |
| FP 20•20 | 152 (5.984) | 119 (4.685) | | 5,3 (11.69) |
| FP 20•25 | 160 (6.299) | 112 (4.409) | G 3/4 | 5,9 (13.01) |
| FP 20•31,5 | 170 (6.693) | 122 (4.803) | | 6 (13.23) |
| FP 20•36 | 175,5 (6.909) | 116,5 (4.587) | | 6,3 (13.89) |
| FP 20•40 | 181 (7.126) | 122 (4.803) | | 6,6 (14.55) |

How to order:

FP 20•8 B0-13T1-L GD/GD-N

GAS STRAIGHT THREAD PORTS
British standard pipe parallel (55°) conforms to UNI - ISO 228

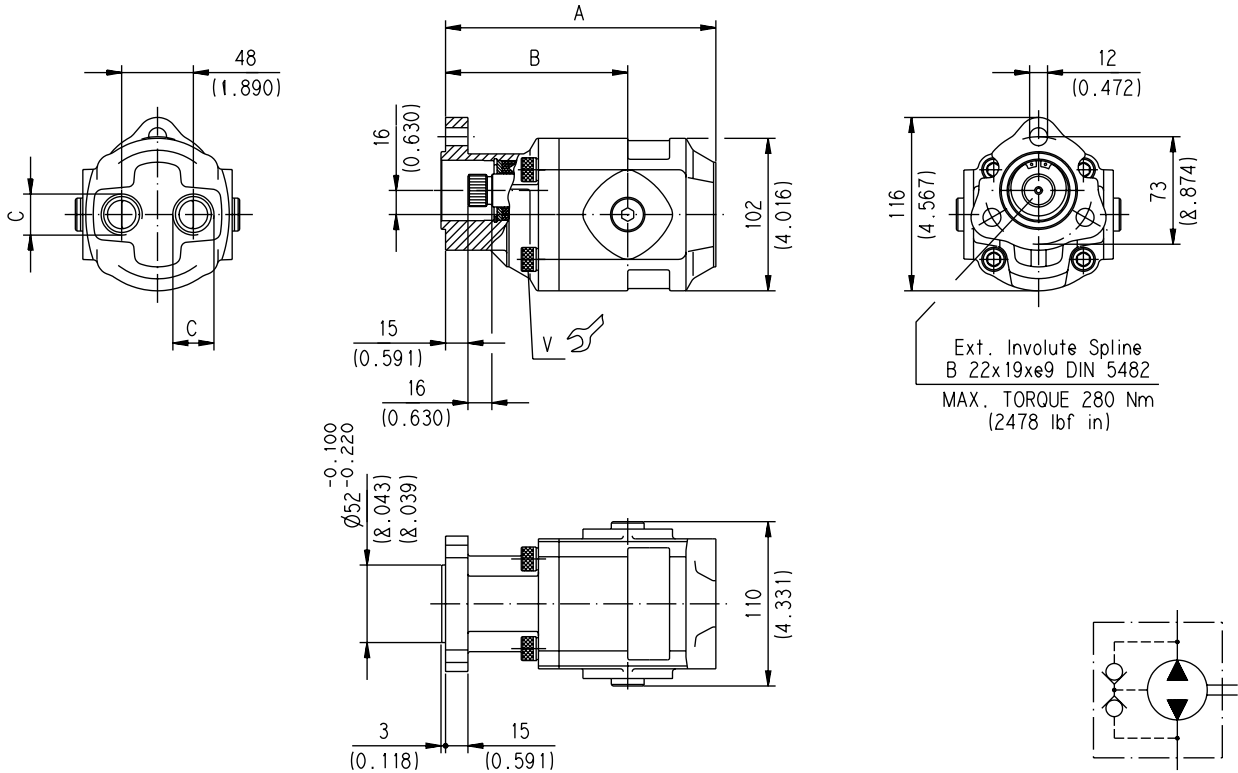

D 100-D47/0805

Standard version pumps have reversible rotation and internal drain.

The version with rear ports allow, removing the lateral plugs all possible combination ports.

Screw tightening torque Nm (lbf in)

| |
|-------------------|
| V |
| 70 ±7 (558 ÷ 682) |

| Pump type | A | | C | Mass | |
|-------------------|---------------|---------------|----------|-------------|--|
| | mm (in) | mm (in) | | kg (lbs) | |
| FP 20•8 | 129 (5.079) | 105 (4.134) | G 1/2 | 4,8 (10.58) | |
| FP 20•11,2 | 132,5 (5.217) | 108,5 (4.272) | | 5 (11.03) | |
| FP 20•16 | 142 (5.591) | 112,5 (4.429) | | 5,2 (11.47) | |
| FP 20•20 | 148,5 (5.846) | 119 (4.685) | | 5,3 (11.69) | |
| FP 20•25 | 156,5 (6.161) | 112 (4.409) | G 3/4 | 5,9 (13.01) | |
| FP 20•31,5 | 166,5 (6.555) | 122 (4.803) | | 6 (13.23) | |
| FP 20•36 | 172,5 (6.791) | 116,5 (4.587) | | 6,3 (13.89) | |
| FP 20•40 | 178 (7.008) | 122 (4.803) | | 6,6 (14.55) | |

How to order:

FP 20•11,2 B0-13T1-P GD/GD-N

01/08.2005

GAS STRAIGHT THREAD PORTS
British standard pipe parallel (55°) conforms to UNI - ISO 228

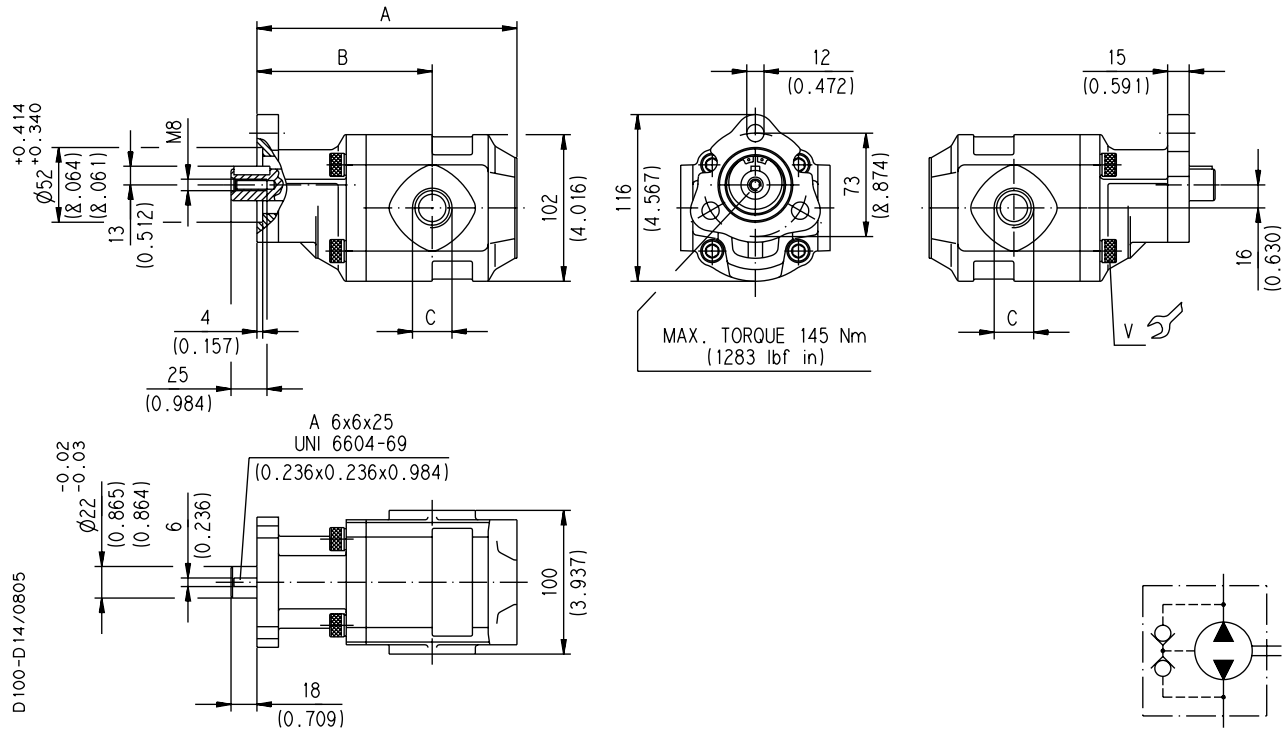

Standard version pumps have reversible rotation and internal drain.

Screw tightening torque Nm (lbf in)

| |
|--------------------------|
| V |
| 70 ±7 (558 ÷ 682) |

01/08.2005

| Pump type | A | B | C | Mass |
|-------------------|---------------|---------------|----------|-------------|
| | mm (in) | mm (in) | | kg (lbs) |
| FP 20•16 | 145,5 (5.728) | 112,5 (4.429) | G 1/2 | 5,2 (11.47) |
| FP 20•20 | 152 (5.984) | 119 (4.685) | | 5,3 (11.69) |
| FP 20•25 | 160 (6.299) | 112 (4.409) | G 3/4 | 5,9 (13.01) |
| FP 20•31,5 | 170 (6.693) | 122 (4.803) | | 6 (13.23) |
| FP 20•40 | 181 (7.126) | 122 (4.803) | | 6,6 (14.55) |

How to order:

FP 20•16 B0-43TO-L GD/GD-N

GAS STRAIGHT THREAD PORTS
British standard pipe parallel (55°) conforms to UNI - ISO 228

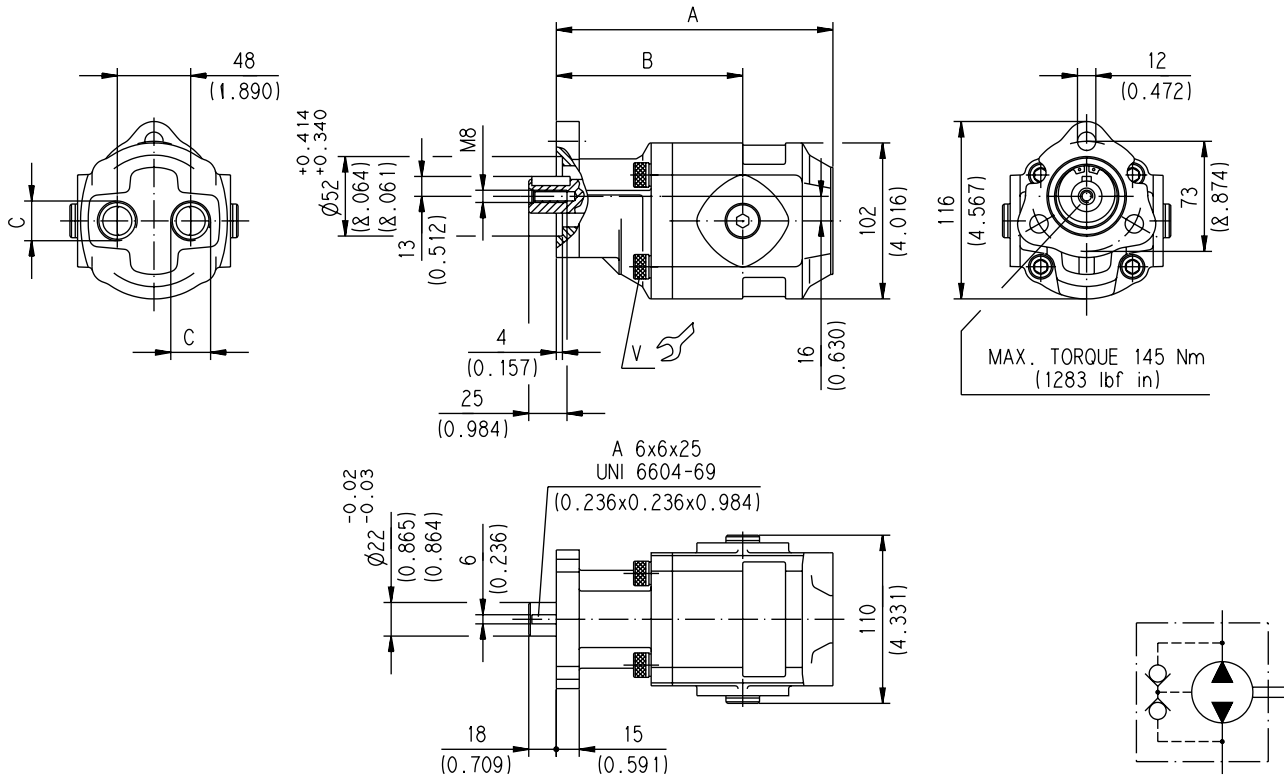

D 100-D48/0805

Standard version pumps have reversible rotation and internal drain.

The version with rear ports allow, removing the lateral plugs all possible combination ports.

Screw tightening torque Nm (lbf in)

| |
|------------------------|
| V |
| 70 ± 7 (558 ÷ 682) |

| Pump type | | A | | C | Mass |
|-------------------|-----------------------------|---------------|---------------|----------|-------------|
| | | mm (in) | mm (in) | | |
| FP 20•16 | B0-43T0-P GD/GD-N | 142 (5.591) | 112,5 (4.429) | G 1/2 | 5,2 (11.47) |
| FP 20•20 | | 148,5 (5.846) | 119 (4.685) | | 5,3 (11.69) |
| FP 20•25 | | 156,5 (6.161) | 112 (4.409) | | 5,9 (13.01) |
| FP 20•31,5 | B0-43T0-(L)P GE/GE-N | 166,5 (6.555) | 122 (4.803) | G 3/4 | 6 (13.23) |
| FP 20•40 | | 178 (7.008) | 122 (4.803) | | 6,6 (14.55) |

How to order

FP 20•16 B0-43T0-P GD/GD-N

01/08.2005

GAS STRAIGHT THREAD PORTS

British standard pipe parallel (55°) conforms to UNI - ISO 228

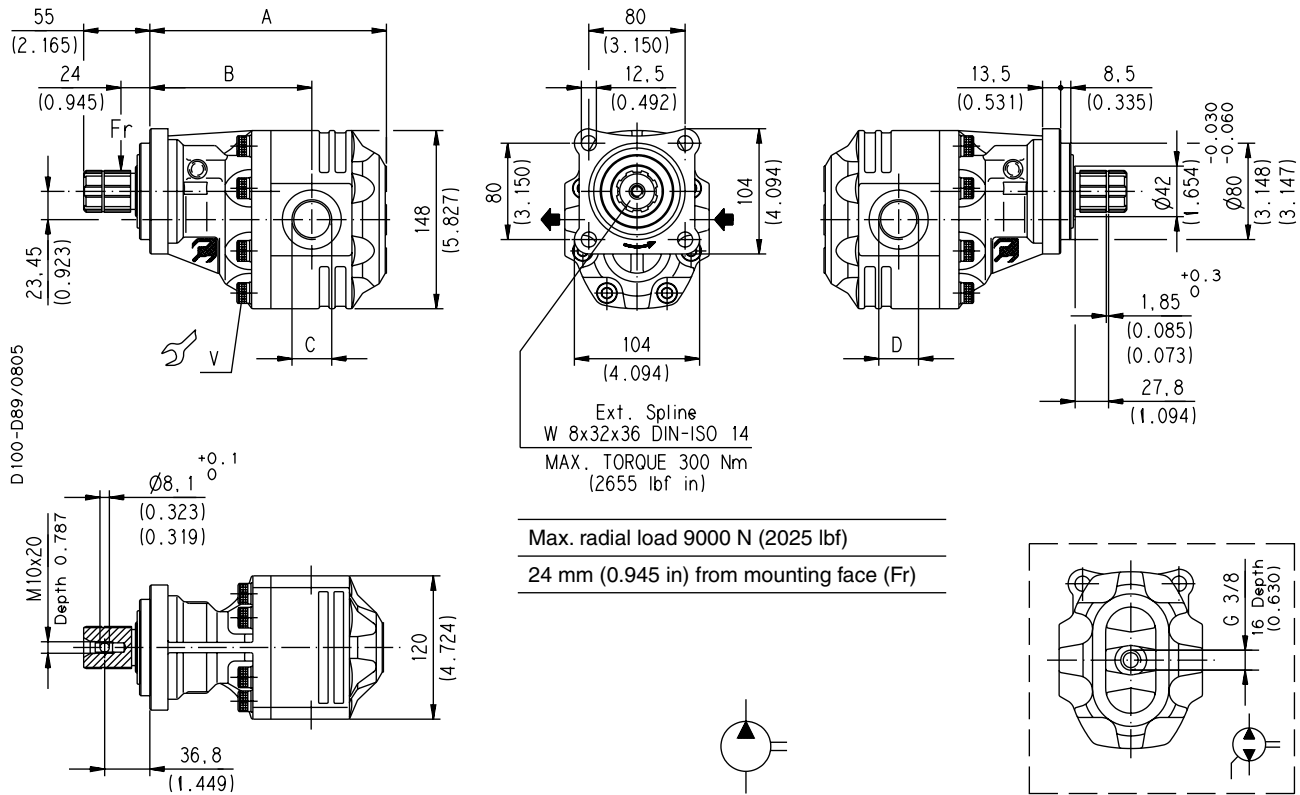

Multiple pumps available.

For the applications without radial load is available the light weight version without outboard bearing.

(For more information please consult our technical sales department).

Screw tightening torque Nm (lbf in)

| |
|------------------------------|
| V |
| 70 ⁺⁷ (558 ÷ 682) |

01/08.2005

| Pump type | A | B | C | D | Mass | |
|--|------------------|---------------|---------------|---------|---------------|---------------|
| | | | | | kg (lbs) | |
| S D R B 0-16 Z0 | L GD/GD-N | 168,5 (6.634) | 118,5 (4.665) | G 1/2 | G 1/2 | 10,65 (23.48) |
| | | 174,5 (6.870) | 124,5 (4.902) | | | 11,10 (24.48) |
| | L GE/GE-N | 179,5 (7.067) | 124,5 (4.902) | G 3/4 | G 3/4 | 11,56 (25.49) |
| | | 182,5 (7.185) | 127,5 (5.020) | | | 12,10 (26.68) |
| | | 185,5 (7.303) | 130,5 (5.138) | | | 12,30 (27.12) |
| | | 190,5 (7.500) | 128,5 (5.059) | | | 12,45 (27.45) |
| | L GF/GF-N | 196,5 (7.736) | 134,5 (5.295) | G1 | G1 | 13,00 (28.67) |
| | | 204,5 (8.051) | 135,5 (5.335) | | | 13,70 (30.21) |
| | L GG/GF-N | 209,5 (8.248) | 140,5 (5.531) | | | 14,05 (30.98) |
| | L GG/GG-N | 226,5 (8.917) | 145,5 (5.728) | G 1 1/4 | G 1 1/4 | 15,55 (34.29) |
| | 242,5 (9.547) | 161,5 (6.358) | | | 17,05 (37.60) | |

Rotation: S=left - D=right - R=reversible - B=reversible internal drain
How to order:

FP 30•17 S0-16Z0-L GD/GD-N

GAS STRAIGHT THREAD PORTS

British standard pipe parallel (55°) conforms to UNI - ISO 228

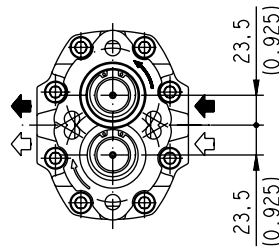
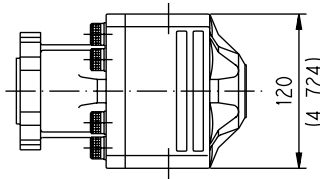
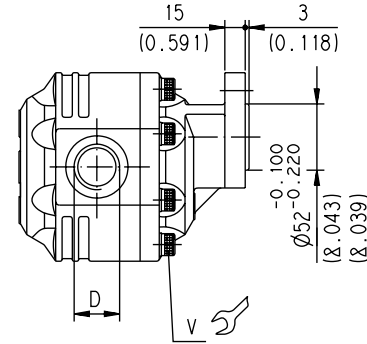
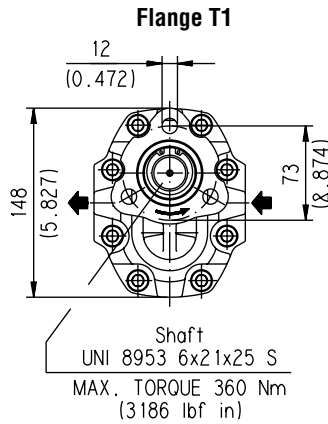
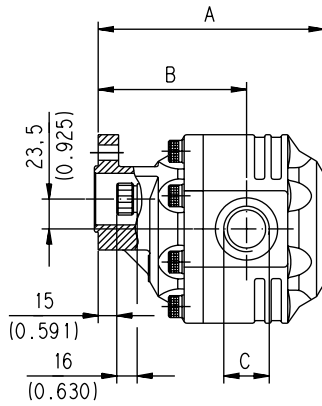

Flange T2
Only for rotation S-D

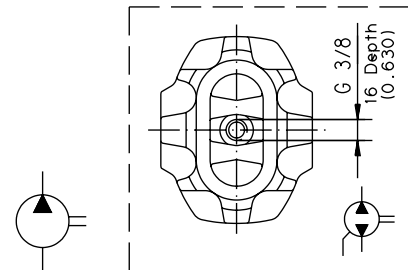

Screw tightening torque Nm (lbf in)

| |
|------------------------------|
| V |
| 70 ^{±7} (558 ÷ 682) |

D 100 - 113 / 0805

01/08.2005

| Pump type | A | B | C | D | Mass |
|----------------------|---------------|---------------|-------|-------|--------------|
| | | | | | |
| FP 30•17 | 150,5 (5.925) | 100,5 (3.957) | G 1/2 | G 1/2 | 9 (19.85) |
| FP 30•27 | | | | | 9,3 (20.51) |
| FP 30•34 | | | | | 9,6 (21.17) |
| FP 30•38 | | | | | 9,8 (21.61) |
| FP 30•43 | | | | | 10 (22.05) |
| FP 30•51 | | | | | 10,3 (22.71) |
| FP 30•61 | | | | | 10,7 (23.59) |
| FP 30•73 | | | | | 10,9 (24.03) |
| FP 30•82 | | | | | 11 (24.26) |
| FP 30•100 (●) | | | | | 217 (8.543) |
| FP 30•125 (●) | 12,3 (27.12) | | | | |

Rotation: S=left - D=right - R=reversible - B=reversible internal drain
How to order:

(●) Only available in T1 version.

FP 30•17 S0-19T1-L GD/GD-N

GAS STRAIGHT THREAD PORTS

British standard pipe parallel (55°) conforms to UNI - ISO 228

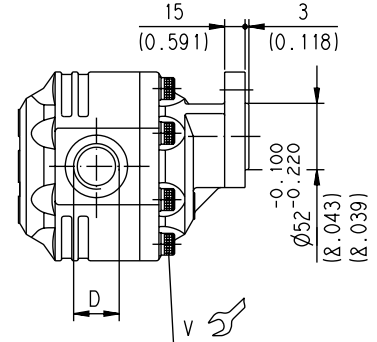
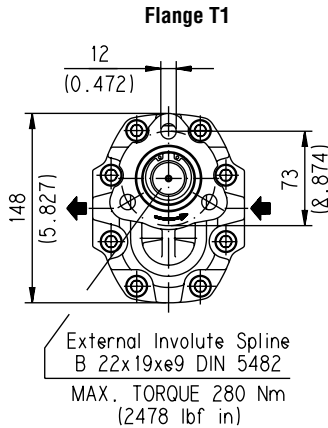
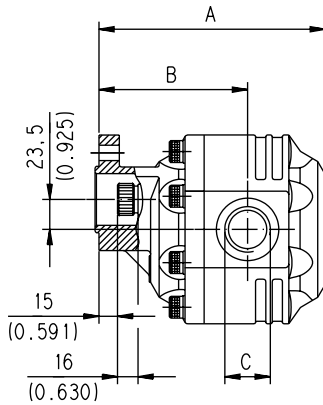

D100-D39/0805

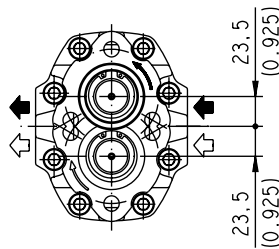
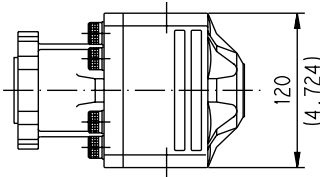

Flange T2
Only for rotation S-D

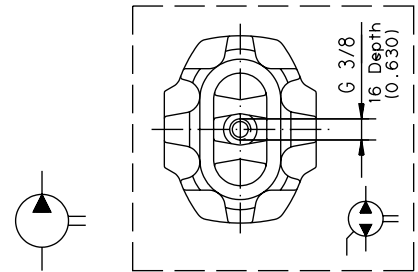

Screw tightening torque Nm (lbf in)

| |
|--------------------------|
| V |
| 70 ±7 (558 ÷ 682) |

01/08.2005

| Pump type | S D R B | 0-13 | T1 T2 | L GF/GF-N L GG/GF-N | A | B | C | D | Mass |
|-----------------|------------------|------|----------|------------------------|---------------|---------------|----------|----------|--------------|
| | | | | | mm (in) | mm (in) | IN | OUT | kg (lbs) |
| FP 30•61 | | | T1 | L GF/GF-N | 178,5 (7.028) | 116,5 (4.587) | G 1 | G 1 | 10,7 (23.59) |
| FP 30•82 | | | T2 | L GG/GF-N | 191,5 (7.539) | 122,5 (4.823) | G 1 1/4 | | 11 (24.26) |

Rotation: S=left - D=right - R=reversible - B=reversible internal drain
How to order:

FP 30•61S0-13T1-L GF/GF-N

GAS STRAIGHT THREAD PORTS
British standard pipe parallel (55°) conforms to UNI - ISO 228

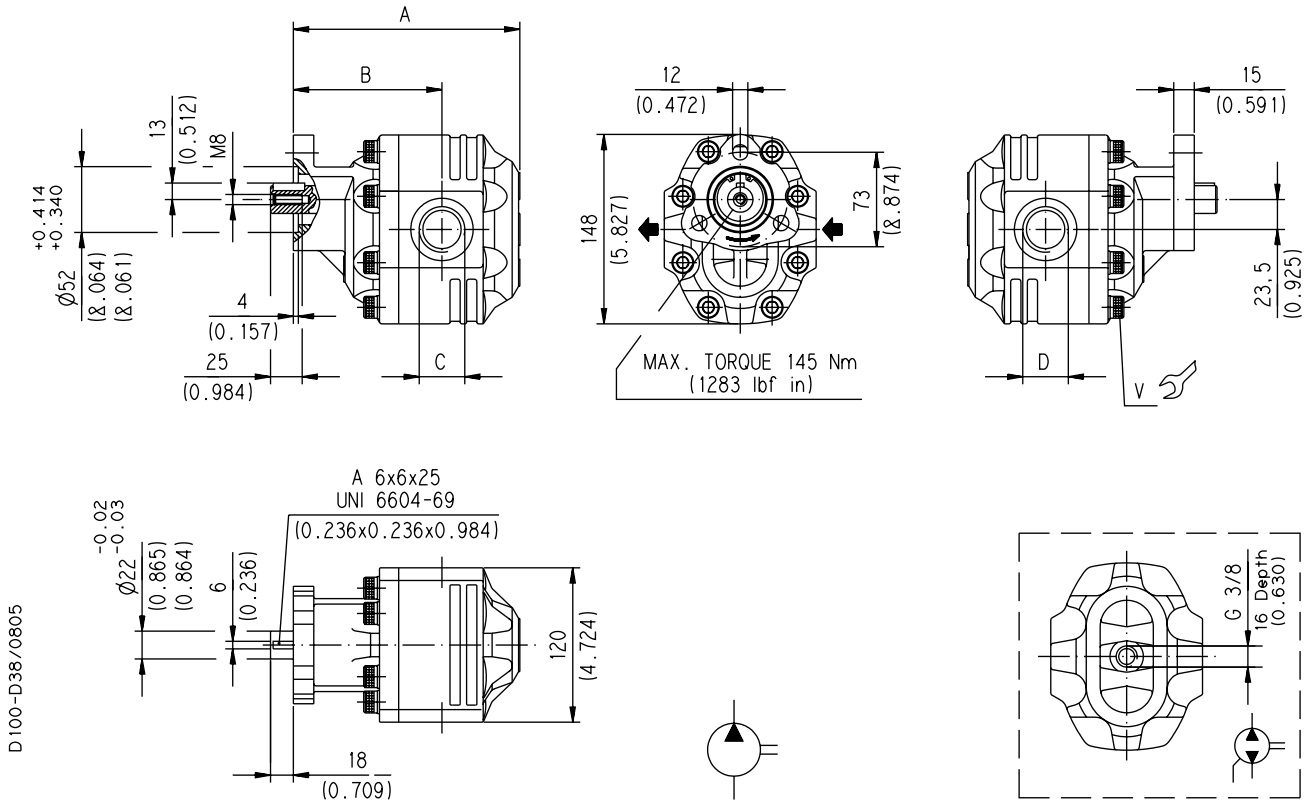

Screw tightening torque Nm (lbf in)

| |
|--------------------------|
| V |
| 70 ±7 (558 ÷ 682) |

| Pump type | | | A | B | C | D | Mass |
|-----------------|--|--------------------------|---------------|---------------|---------|-----|--------------|
| | | | mm (in) | mm (in) | IN | OUT | kg (lbs) |
| FP 30•61 | S D R B | 0-43-T0-L GF/GF-N | 178,5 (7.028) | 116,5 (4.587) | G 1 | | 10,7 (23.59) |
| FP 30•82 | | | 191,5 (7.539) | 122,5 (4.823) | G 1 1/4 | G 1 | 11 (24.26) |

Rotation: S=left - D=right - R=reversible - B=reversible internal drain
How to order:

FP 30•61S0-43T0-L GF/GF-N

01/08.2005

FORMULA 30

HYDRAULIC GEAR PUMPS SAE STANDARD

SAE

SAE STRAIGHT THREAD PORTS J514
American straight thread UNC-UNF 60° conforms to ANSI B 1.1.

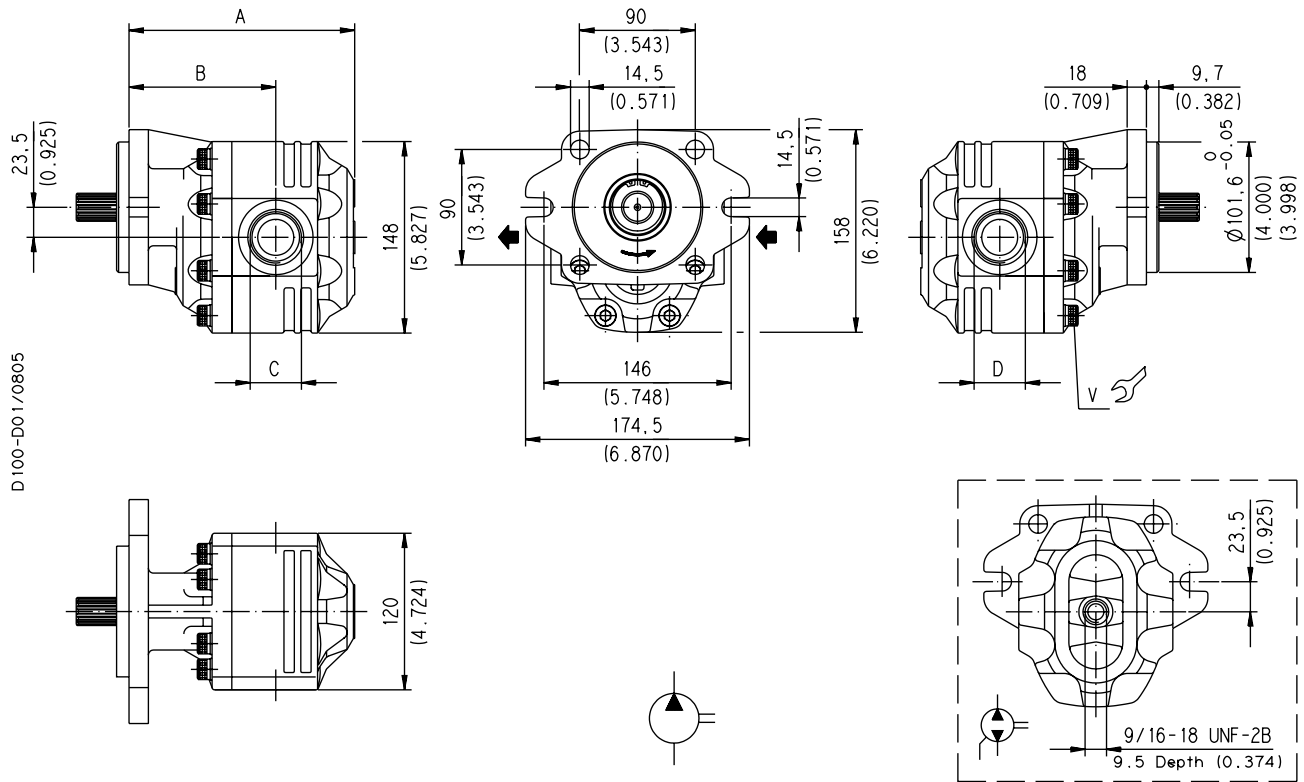

To order see page 28 - 30

Screw tightening torque Nm (lbf in)

V

70 ±7 (558 ÷ 682)

01/08.2005

| Pump type | A | B | C | D | Ports code | | Mass |
|---------------------|-------------|-------------|-----------------|-----------------|------------|-----------|--------------|
| | mm (in) | mm (in) | IN | OUT | IN | OUT | kg (lbs) |
| FP 30•17 (●) | 148 (5.827) | 98 (3.858) | 3/4-16 UNF-2B | 3/4-16 UNF-2B | OB | OB | 10,4 (22.93) |
| FP 30•27 | 154 (6.063) | 104 (4.094) | | | | | 10,8 (23.81) |
| FP 30•34 | 159 (6.260) | 104 (4.094) | 1-1/16-12 UN-2B | | OD | OD | 11,3 (24.92) |
| FP 30•38 | 162 (6.378) | 107 (4.213) | | 1-1/16-12 UN-2B | | | 11,5 (25.36) |
| FP 30•43 | 165 (6.496) | 110 (4.331) | | | | | 11,8 (26.02) |
| FP 30•51 | 170 (6.693) | 108 (4.252) | 1-5/16-12 UN-2B | | OF | | 12 (26.46) |
| FP 30•61 | 176 (6.929) | 114 (4.488) | | 1-3/16-12 UN-2B | | OE | 13 (28.67) |
| FP 30•73 | 184 (7.244) | 115 (4.528) | 1-5/8-12 UN-2B | 1-5/16-12 UN-2B | OG | OF | 13,4 (29.55) |
| FP 30•82 | 189 (7.441) | 120 (4.724) | | | | | 13,9 (30.65) |

(●) Only available in version 2.

FORMULA 30 SAE VERSION

SAE

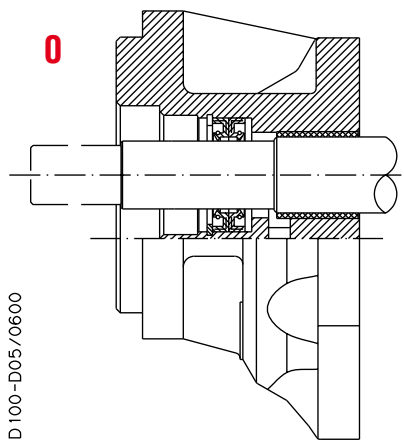

Version for applications without radial and axial load on the drive shaft.

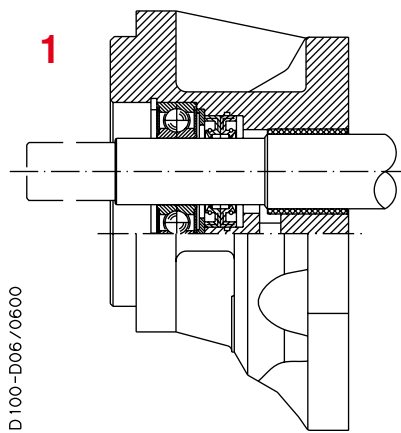

Version for applications with low radial load and without axial load on the drive shaft.

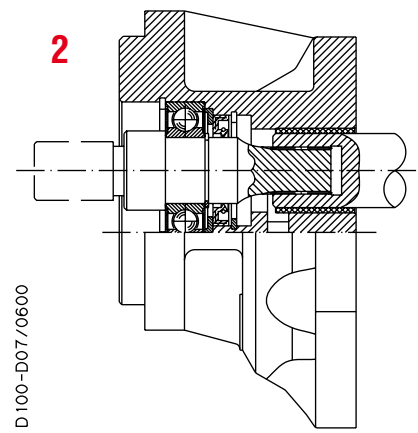

Special version with independent shaft for applications with low radial load and without axial load on the drive shaft.

FORMULA 30 SAE END DRIVE SHAFTS

SAE

SAE "B" SPLINE

04

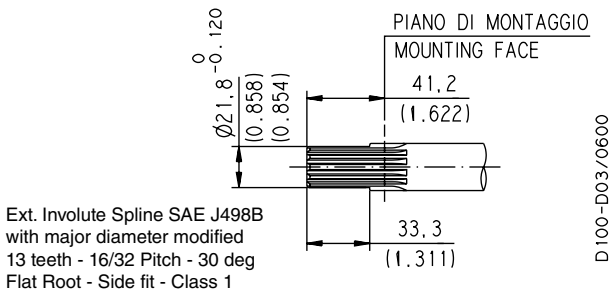

MAX 330 Nm (2921 lbf in) ◆

SAE "B" STRAIGHT

32

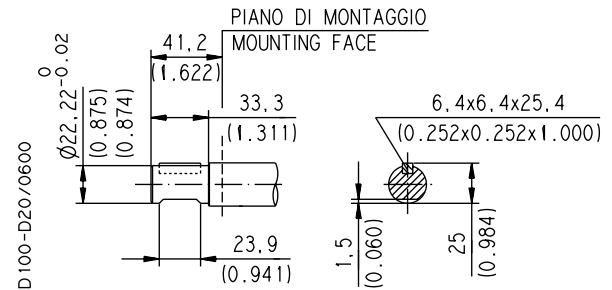

SAE "BB" SPLINE

05

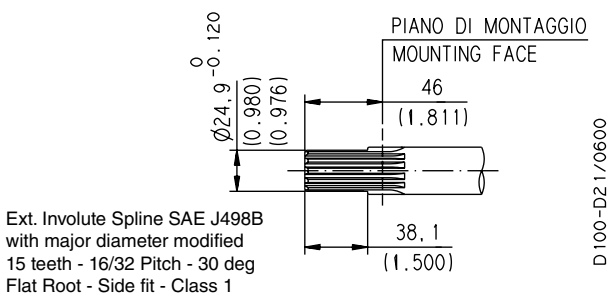

MAX 500 Nm (4426 lbf in) ◆

SAE "BB" STRAIGHT

33

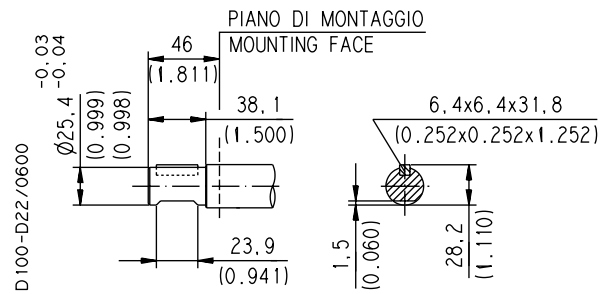

01/08.2005

◆ For "2" version whichever end shaft, the max. torque applicable is $M=170 \text{ Nm (1505 lbf in)}$

FORMULA 30 PERMISSIBLE RADIAL LOADING

SAE

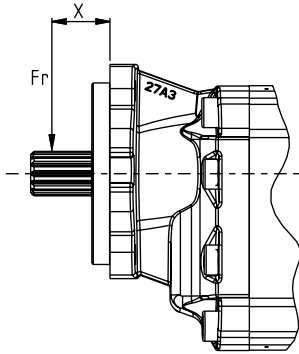

X = Distance of the radial load result from the mounting flange.

Fatigue life (hours) $L_n = 1000$ [h]

Each curve has been obtained at

- (1) 1000 min⁻¹ (4) 2500 min⁻¹
- (2) 1500 min⁻¹ (5) 3000 min⁻¹
- (3) 2000 min⁻¹

| |
|----------------|
| VERSION |
| 1-2 |

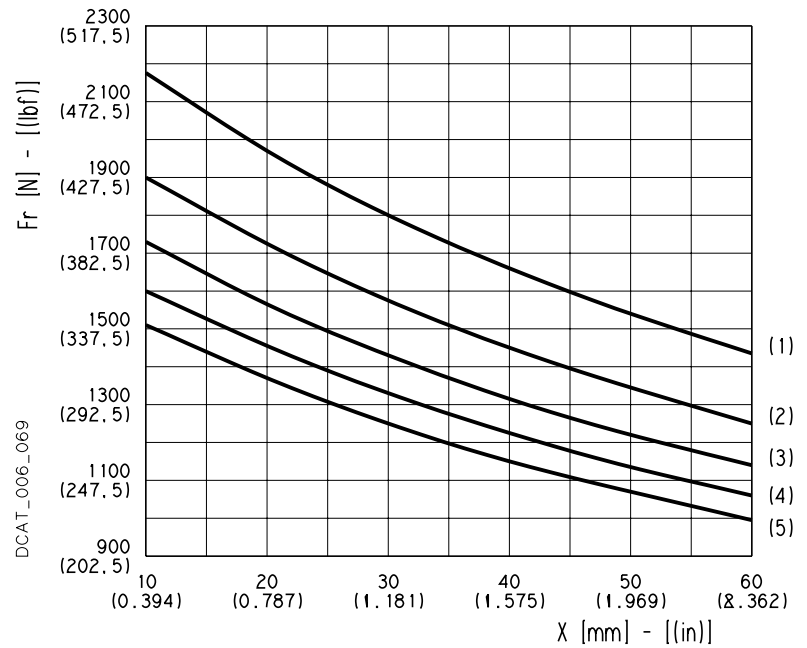

01/08.2005

HOW TO ORDER SINGLE PUMPS

| | | | | | | | |
|----------------|----------|----------|-------------|-----------|------------|--------------|------------|
| 1 | 2 | 3 | 4 | 5 | 6 | 7 | 8 |
| FP30•17 | S | 0 | - 04 | S3 | - L | OB/OB | - N |

| 1 | Pump type | Code |
|---|--|-----------------|
| | 1.05 (17,28) in ³ /rev (cm ³ /rev) | FP 30-17 |
| | 1.63 (26,70) in ³ /rev (cm ³ /rev) | FP 30-27 |
| | 2.11 (34,56) in ³ /rev (cm ³ /rev) | FP 30-34 |
| | 2.40 (39,27) in ³ /rev (cm ³ /rev) | FP 30-38 |
| | 2.68 (43,98) in ³ /rev (cm ³ /rev) | FP 30-43 |
| | 3.16 (51,83) in ³ /rev (cm ³ /rev) | FP 30-51 |
| | 3.74 (61,26) in ³ /rev (cm ³ /rev) | FP 30-61 |
| | 4.50 (73,82) in ³ /rev (cm ³ /rev) | FP 30-73 |
| | 4.98 (81,68) in ³ /rev (cm ³ /rev) | FP 30-82 |

| 2 | Rotation | Code |
|---|--------------------------------|----------|
| | Left | S |
| | Ringht | D |
| | Reversible | R |
| | Reversible with internal drain | B |

| 3 | Version | Code |
|---|--|----------|
| | Without outboard bearing | 0 |
| | With outboard bearing | 1 |
| | With outboard bearing and indep. shaft | 2 |

| 4 | Drive shaft | Code |
|---|----------------------------|-----------|
| | SAE "B" spline (13 teeth) | 04 |
| | SAE "B" straight | 32 |
| | SAE "BB" spline (15 teeth) | 05 |
| | SAE "BB" straigh | 33 |

| 5 | Mounting flange | Code |
|---|-------------------|-----------|
| | SAE "B" 2-4 holes | S3 |

| Code | Ports position | 6 |
|----------|----------------|---|
| L | Side | |

| Code | PORTS IN/OUT | 7 |
|--|--------------|---|
| SAE STRAIGHT THREAD PORTS (ODT) | | |
| Side | Pump type | |
| OB/OB | FP 30•17 | |
| OD/OD | FP 30•27 | |
| OD/OD | FP 30•34 | |
| OD/OD | FP 30•38 | |
| OF/OD | FP 30•43 | |
| OF/OE | FP 30•51 | |
| OF/OE | FP 30•61 | |
| OG/OF | FP 30•73 | |
| OG/OF | FP 30•82 | |

| Code | Seals (b) | 8 |
|-------------|---------------------------------|---|
| N | Buna N (standard) | |
| V | Viton | |
| N Bz | Buna N and Bronze thrust plates | |
| V Bz | Viton and Bronze thrust plates | |

(b) Choose the seals according to the temperature shown on page 3

ORDER EXAMPLE

Standard pump **FP30.27S0-04S3-L0D/OD-N**

Special version pump **FP30.17S2-32S3-LOB/OB-V Bz**

FORMULA 40

HYDRAULIC GEAR PUMPS ISO STANDARD

16 Z0

GAS STRAIGHT THREAD PORTS

British standard pipe parallel (55°) conforms to UNI - ISO 228

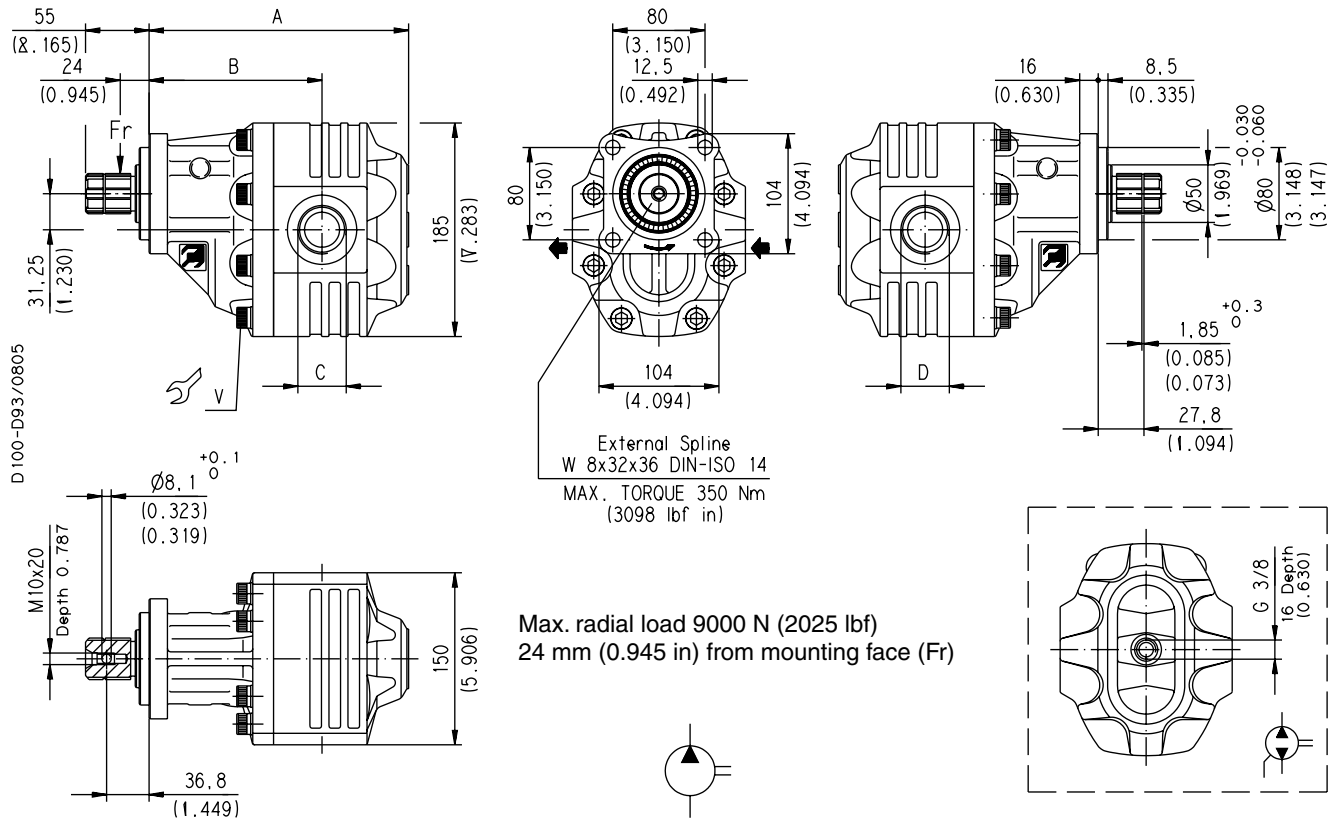

Screw tightening torque Nm (lbf in)

V

100 ±10 (797 ÷ 974)

01/08.2005

| Pump type | A | B | C | D | Mass |
|-----------|-------------|-------------|---------|-------|---------------|
| | | | | | kg (lbs) |
| FP 40•63 | 199 (7.835) | 131 (5.157) | G 1 | G 3/4 | 18,65 (41.12) |
| FP 40•73 | | | | | 19,30 (42.56) |
| FP 40•87 | 208 (8.189) | 140 (5.512) | G 1 1/4 | G1 | 19,75 (43.55) |
| FP 40•109 | | | | | 21 (46.31) |
| FP 40•133 | 225 (8.858) | 150 (5.906) | G 1 1/2 | G1 | 22,10 (48.73) |
| FP 40•151 | | | | | 22,90 (50.49) |

Rotation: S=left - D=right - R=reversible - B=reversible internal drain
How to order:

FP 40•63S0-16Z0-L GF/GE-N

GAS STRAIGHT THREAD PORTS
British standard pipe parallel (55°) conforms to UNI - ISO 228

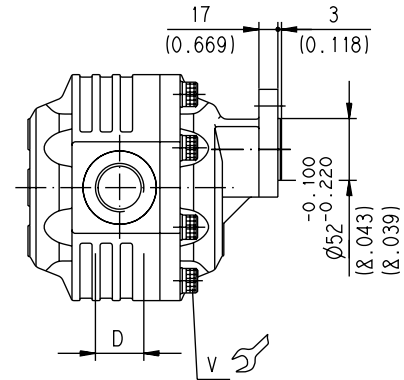
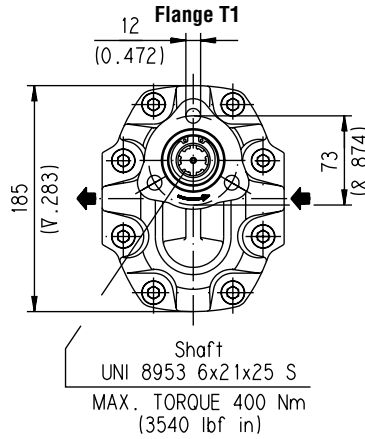
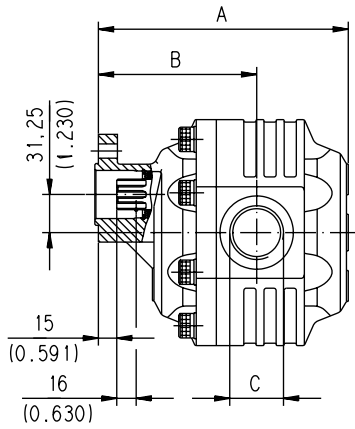

D 100-D10/0805

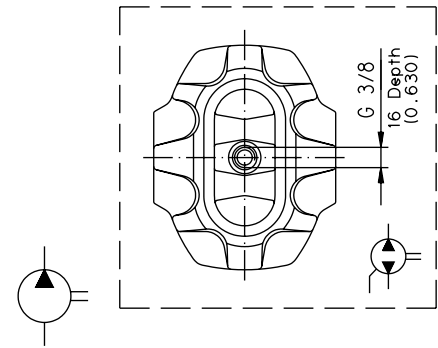
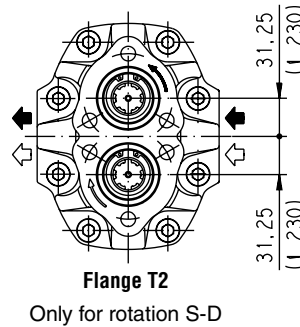
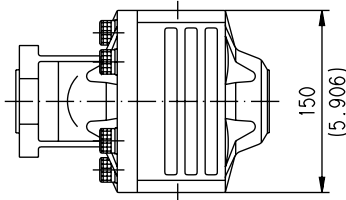

Screw tightening torque Nm (lbf in)

| |
|---------------------|
| V |
| 100 ±10 (797 ÷ 974) |

| Pump type | A | B | C | D | Mass | | | | | | |
|------------------|----------------------------|-------------|-----------|------------------|---------------|------------------|------------------|---------------|---------------|------------|--------------|
| | | | | | | mm (in) | mm (in) | IN | OUT | kg (lbs) | |
| FP 40•63 | S D R B | 0-19 | T1 | L GF/GE-N | 187,5 (7.382) | 119,5 (4.705) | G 1 | G 3/4 | 16,1 (35.50) | | |
| FP 40•73 | | | | | 191,5 (7.539) | 123,5 (4.862) | | | 16,5 (36.38) | | |
| FP 40•87 | | | | | T2 | L GG/GF-N | 196,5 (7.736) | 128,5 (5.059) | G 1 1/4 | 17 (37.49) | |
| FP 40•109 | | | | | | | 204,5 (8.051) | 129,5 (5.098) | | 18 (39.69) | |
| FP 40•133 | | | | | | | L GH/GF-N | 213,5 (8.406) | 138,5 (5.453) | G 1 1/2 | 19,5 (43.00) |
| FP 40•151 | | | | | | | | 219,5 (8.642) | 144,5 (5.689) | | 20 (44.10) |

Rotation: S=left - D=right - R=reversible - B=reversible internal drain
How to order:

FP 40•63S0-19T1-L GF/GE-N

01/08.2005

FORMULA 40

HYDRAULIC GEAR PUMPS SAE STANDARD

SAE

SAE STRAIGHT THREAD PORTS J514
American straight thread UNC-UNF 60° conforms to ANSI B 1.1.

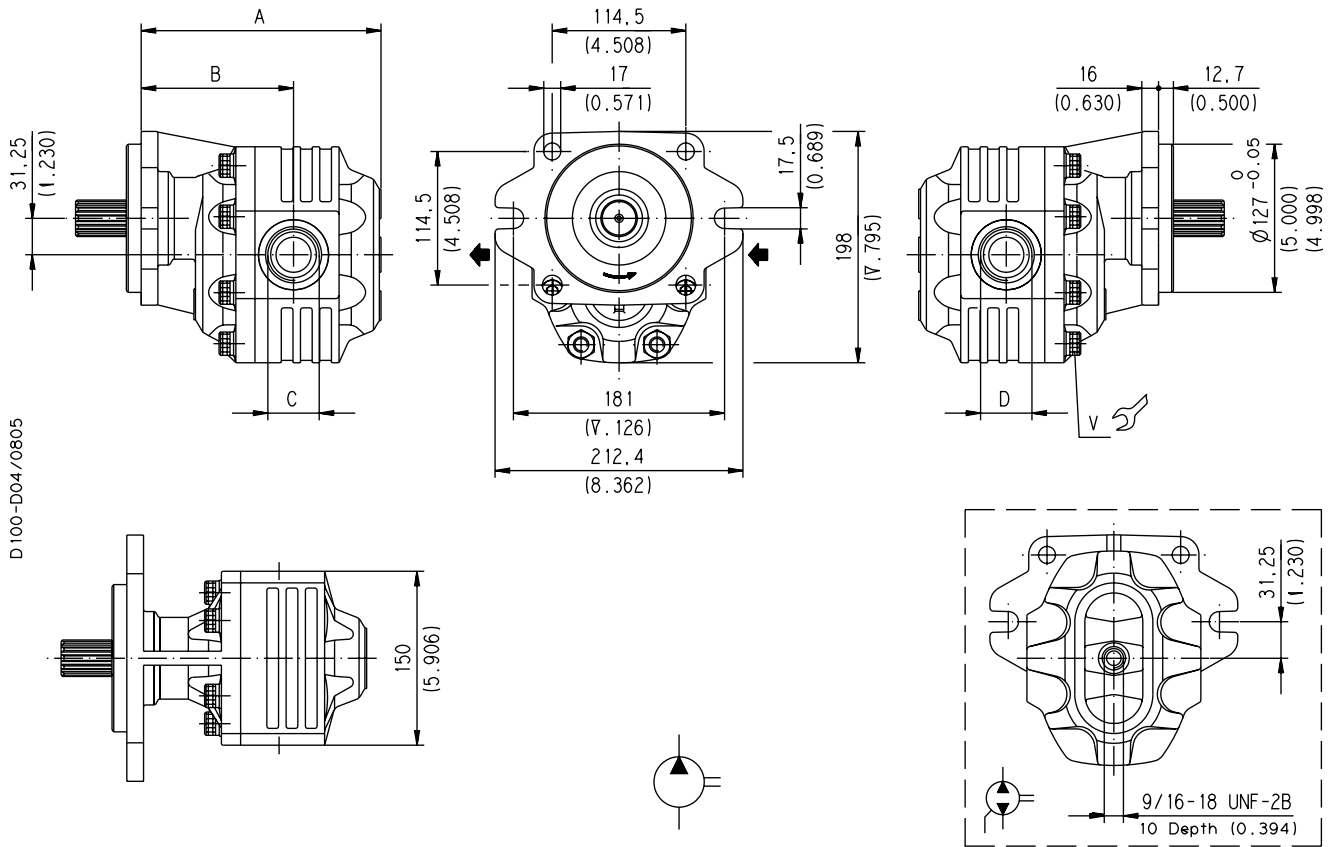

Screw tightening torque Nm (lbf in)

| |
|---------------------|
| V |
| 100 ±10 (797 ÷ 974) |

To order see page 34 - 37

01/08.2005

| Pump type | A | B | C | D | Ports code | | Mass |
|------------------|---------------|---------------|-----------------|-----------------|------------|-----------|--------------|
| | mm (in) | mm (in) | IN | OUT | IN | OUT | kg (lbs) |
| FP 40•63 | 188,5 (7.421) | 120,5 (4.744) | 1-5/16-12 UN-2B | 1-1/16-12 UN-2B | OF | OD | 19,5 (43.00) |
| FP 40•73 | 192,5 (7.579) | 124,5 (4.902) | | | | | 20 (44.10) |
| FP 40•87 | 197,5 (7.776) | 129,5 (5.098) | 1-5/8-12 UN-2B | 1-5/16-12 UN-2B | OG | OF | 20,5 (45.20) |
| FP 40•109 | 205,5 (8.091) | 130,5 (5.138) | | | | | 21 (46.31) |
| FP 40•133 | 214,5 (8.445) | 139,5 (5.492) | 1-7/8-12 UN-2B | | OH | | 23 (50.72) |
| FP 40•151 | 220,5 (8.681) | 145,5 (5.728) | | | | | 25 (55.13) |

FORMULA 40 SAE VERSION

SAE

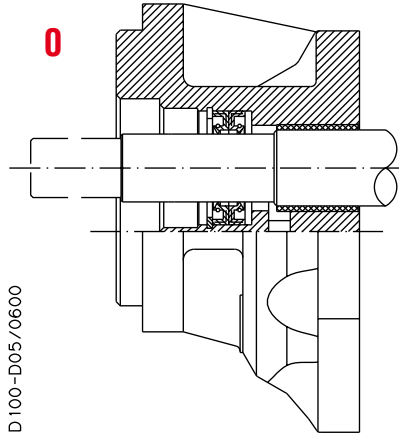

Version for applications without radial and axial load on the drive shaft.

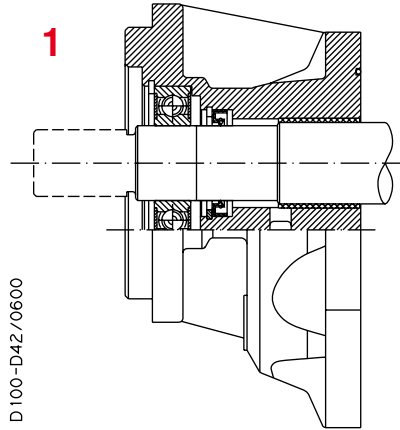

Version for applications with low radial load and without axial load on the drive shaft.

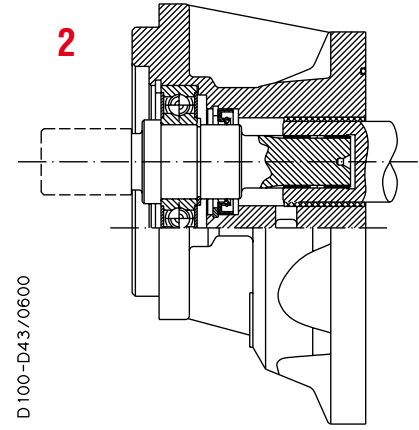

Special version with independent shaft for applications with low radial load and without axial load on the drive shaft.

FORMULA 40 SAE END DRIVE SHAFTS

SAE

SAE "C" SPLINE

06

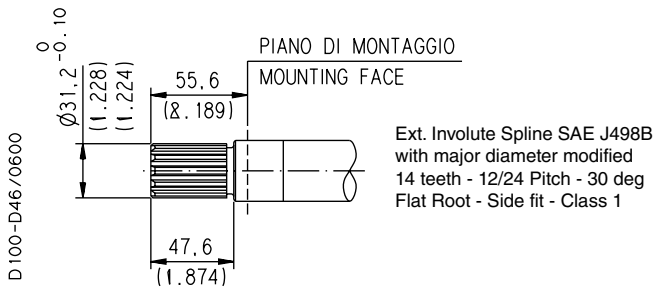

MAX 900 Nm (7966 lbf in) ◆

SAE "C" STRAIGHT

34

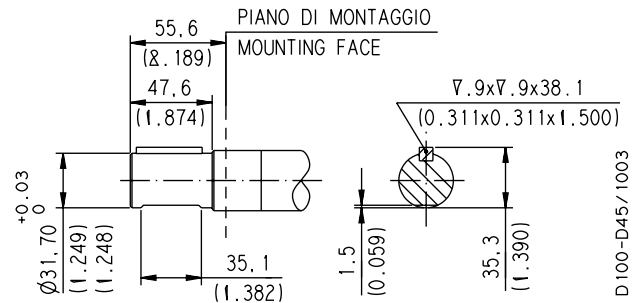

MAX 600 Nm (5311 lbf in) ◆

◆For "2" version whichever and shaft, the max. torque applicable is M= 600 Nm (5311 lbf in)

PUMP - VERSION - SHAFT AVAILABILITY TABLE

SAE

| Pump type | VERSION | | |
|-------------|---------|---------|---------|
| | 0 | 1 | 2 |
| FP 40 • 63 | 06 | 06 | 06 - 34 |
| FP 40 • 73 | 06 - 34 | 06 - 34 | 06 - 34 |
| FP 40 • 87 | 06 - 34 | 06 - 34 | 06 - 34 |
| FP 40 • 109 | 06 | 06 | 06 - 34 |
| FP 40 • 133 | 06 - 34 | 06 - 34 | 06 - 34 |
| FP 40 • 151 | 06 - 34 | 06 - 34 | 06 - 34 |

SHAFT

01/08.2005

FORMULA 40 PERMISSIBLE RADIAL LOADING

SAE

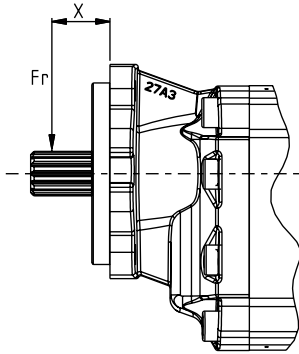

X = Distance of the radial load result from the mounting flange.

Fatigue life (hours) $L_n = 1000$ [h]

Each curve has been obtained at

- (1) 1000 min^{-1} (4) 2500 min^{-1}
- (2) 1500 min^{-1} (5) 3000 min^{-1}
- (3) 2000 min^{-1}

| |
|----------------|
| VERSION |
| 1-2 |

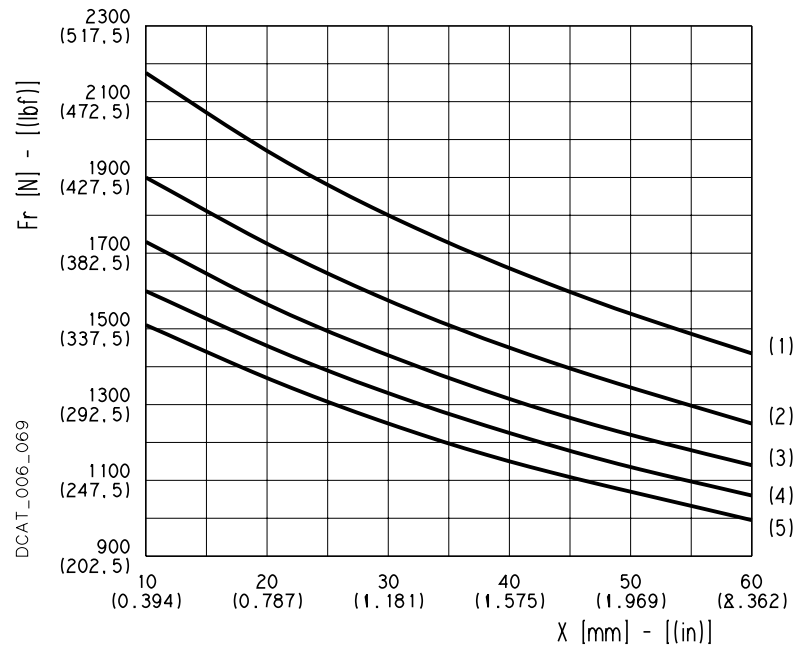

01/08.2005

HOW TO ORDER SINGLE PUMPS

| | | | | | | | |
|----------------|----------|----------|-------------|-----------|------------|--------------|------------|
| 1 | 2 | 3 | 4 | 5 | 6 | 7 | 8 |
| FP40•63 | S | 0 | - 06 | S8 | - L | OF/OD | - N |

| 1 | Pump type | Code |
|---|---|------------------|
| | 3.75 (61,43) in ³ /rev (cm ³ /rev) | FP 40-63 |
| | 4.43 (72,60) in ³ /rev (cm ³ /rev) | FP 40-73 |
| | 5.28 (86,56) in ³ /rev (cm ³ /rev) | FP 40-87 |
| | 6.64 (108,90) in ³ /rev (cm ³ /rev) | FP 40-109 |
| | 8.18 (134,03) in ³ /rev (cm ³ /rev) | FP 40-133 |
| | 9.20 (150,79) in ³ /rev (cm ³ /rev) | FP 40-151 |

| 2 | Rotation | Code |
|---|--------------------------------|----------|
| | Left | S |
| | Right | D |
| | Reversible | R |
| | Reversible with internal drain | B |

| 3 | Version | Code |
|---|--|----------|
| | Without outboard bearing | 0 |
| | With outboard bearing | 1 |
| | With outboard bearing and indep. shaft | 2 |

| 4 | Drive shaft | Code |
|---|---------------------------|-----------|
| | SAE "C" spline (14 teeth) | 06 |
| | SAE "C" straight | 34 |

| 5 | Mounting flange | Code |
|---|-------------------|-----------|
| | SAE "C" 2-4 holes | S8 |

| Code | Ports position | 6 |
|----------|----------------|---|
| L | Side | |

| Code | PORTS IN/OUT | 7 |
|--------------|--------------|---|
| Side | Pump type | |
| OF/OD | FP 40•63 | |
| OF/OD | FP 40•73 | |
| OG/OF | FP 40•87 | |
| OG/OF | FP 40•109 | |
| OH/OF | FP 40•133 | |
| OH/OF | FP 40•151 | |

| Code | Seals (a) | 8 |
|-------------|---------------------------------|---|
| N | Buna N (standard) | |
| V | Viton | |
| N Bz | Buna N and Bronze thrust plates | |
| V Bz | Viton and Bronze thrust plates | |

(a) Choose the seals according to the temperature shown on page 3

ORDER EXAMPLE

Standard pump **FP40.63S0-06S8-LOF/OD-N**

Special version pump **FP40.63S2-34S8-LOF/OD-V Bz**

MULTIPLE PUMPS

FORMULA series pumps can be coupled together in combination. Where input power requirement of each element varies, that with the greater requirement must be at the drive shaft end, and progressively smaller to the rear.

Features and performances are the same as the corresponding single pumps, but pressures must be limited by the transmissible torque of the drive and connecting shafts. To have appropriate data, use the formula below.

The maximum rotational speed is that of the lowest rated speed of the single units incorporated.

Replaces: 01/08.2005

| | | |
|---------------------------------------|---|-----------------------------|
| M | lbf in [Nm] | Torque |
| V | in ³ /rev [cm ³ /rev] | Displacement |
| Δp | psi [bar] | Pressure |
| $\eta_{hm} = \eta_m (V, \Delta p, n)$ | (≈ 0,90) | Hydro-mechanical efficiency |

$$M = \frac{M_{theor.}}{\eta_{hm}} \quad [Nm]$$

$$M_{theor.} = \frac{\Delta p \text{ (bar)} \cdot V \text{ (cm}^3\text{/rev)}}{62,83}$$

DRIVE SHAFT SELECTION

The torque absorbed from the shaft of the first pump results from the sum of the torques due to all single stages. The achieved value must not exceed the maximum torque limit given for the shaft of the first pump. Diagrams providing approximate selection data will be found on page 38.

03/05.2013

Example

Let us consider a double pump FP40•63+ FP30•61. If we suppose that we have to work with the first pump at a pressure of 2900 psi (200 bar) and the second pump at a pressure of 2175 psi (150 bar), the graph 1 shows that the torque absorbed by FP40•63 is 1974 lbf in (223 Nm) and the graph 2 shows that the torque absorbed by FP30•61 is 1416 lbf in (160 Nm) [acceptable value because it don't exceed the maximum drive shaft torque that is 2478 lbf in (280 Nm), see page 42]. The torque to be transmitted by the first drive shaft will thus be 1974+1416=3390 lbf in (223+160= 383 Nm), this value must not exceed the shaft's maximum rated value.

ABSORBED TORQUE

FP 40 (1)

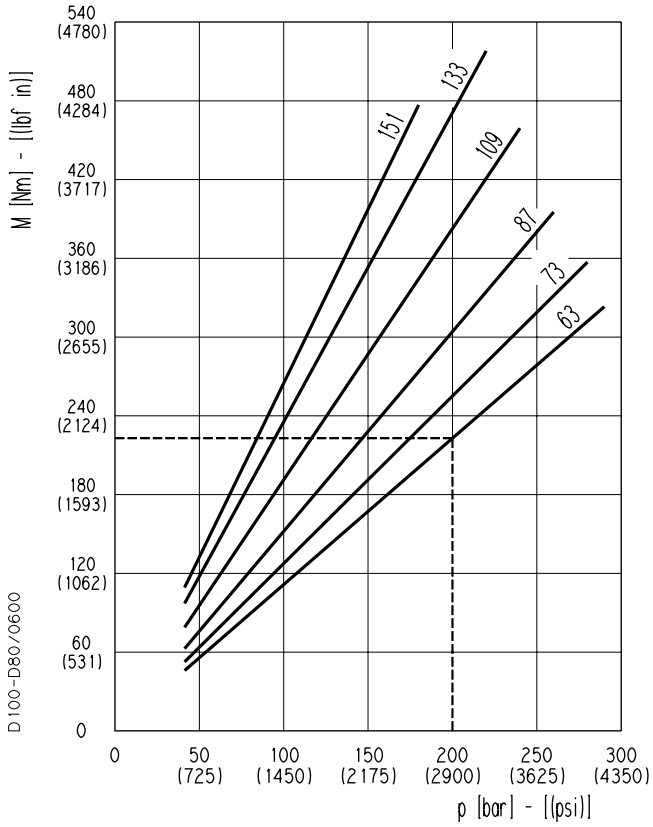

FP 30 (2)

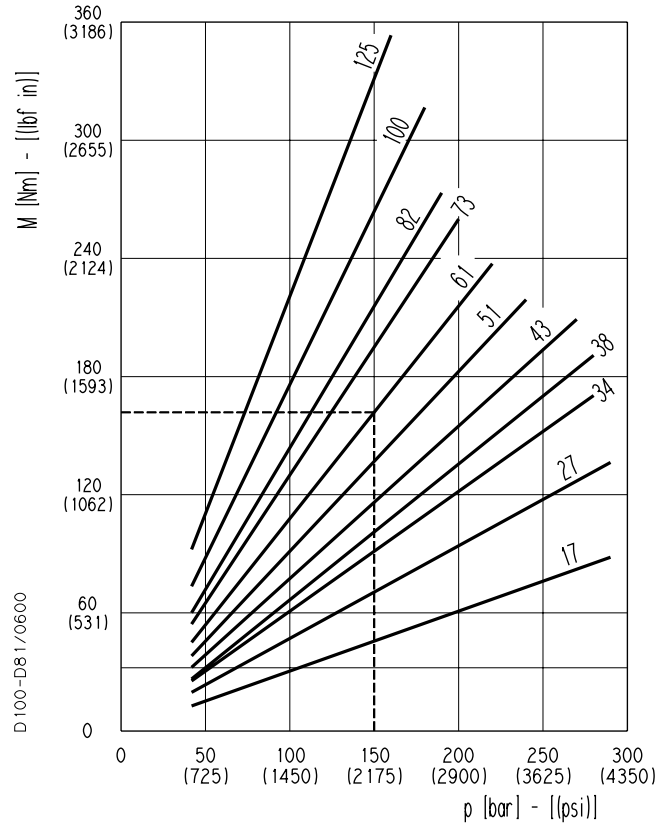

FP 20 (3)

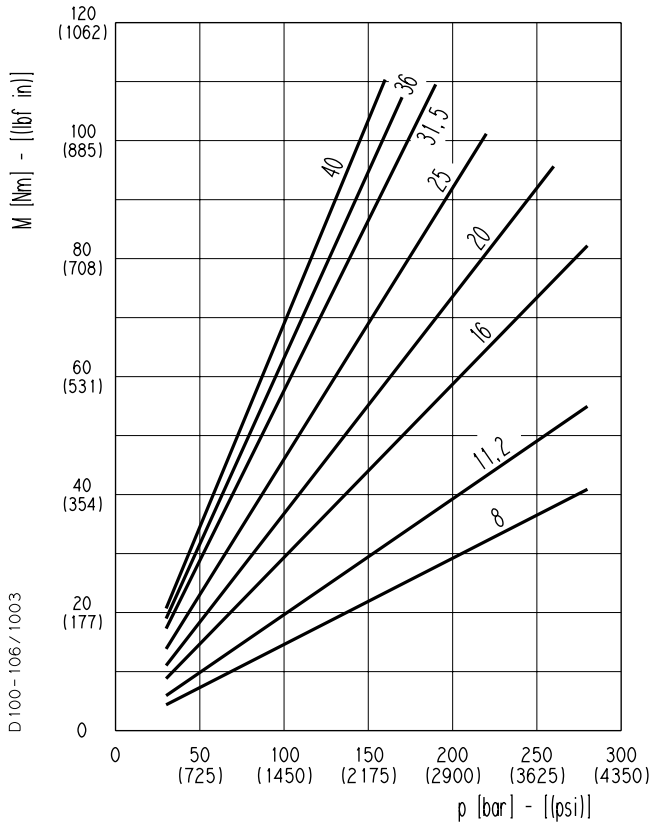

KP 20-PLP 20 (4)

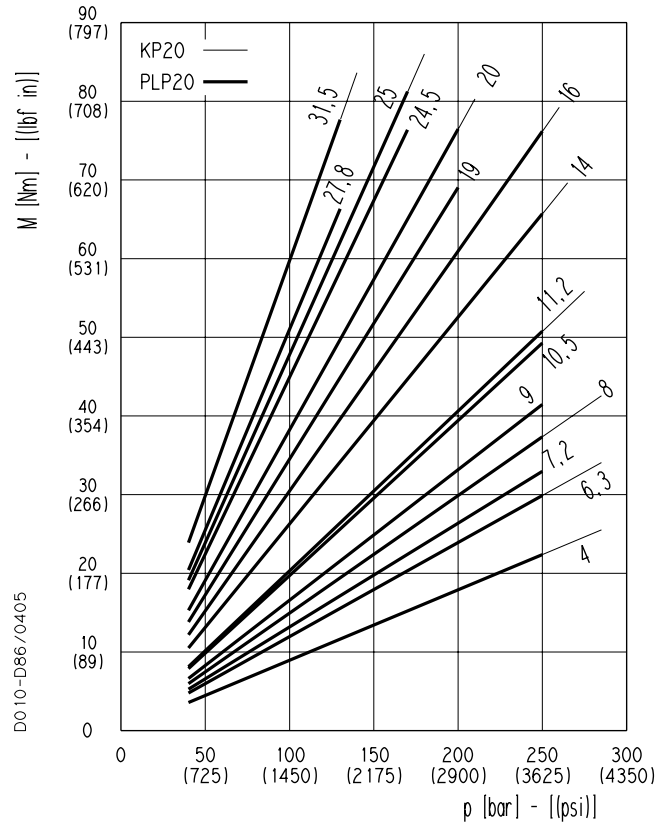

01/08.2005

FORMULA 20

MULTIPLE PUMPS COMBINATION

FORMULA 20 + FORMULA 20

STANDARD VERSION

Front

Rear

D100-104/0600

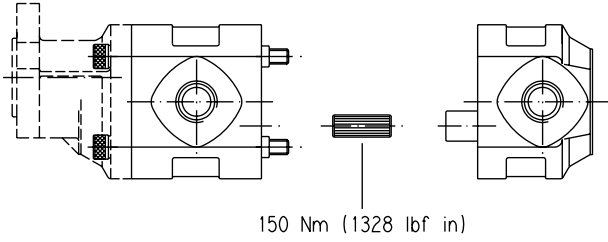

150 Nm (1328 lbf in)

FORMULA 20 END DRIVE SHAFT

ITALIAN STANDARD

13

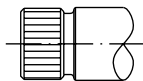

MAX 280 Nm (2478 lbf in)

01/08.2005

FORMULA 30

MULTIPLE PUMPS COMBINATION

FORMULA 30 + FORMULA 30 STANDARD VERSION

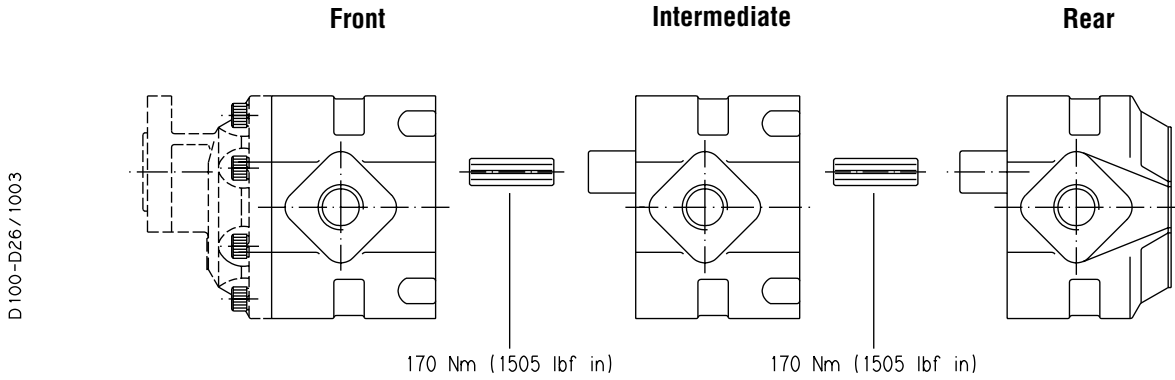

FORMULA 30 + KAPPA 20 STANDARD VERSION

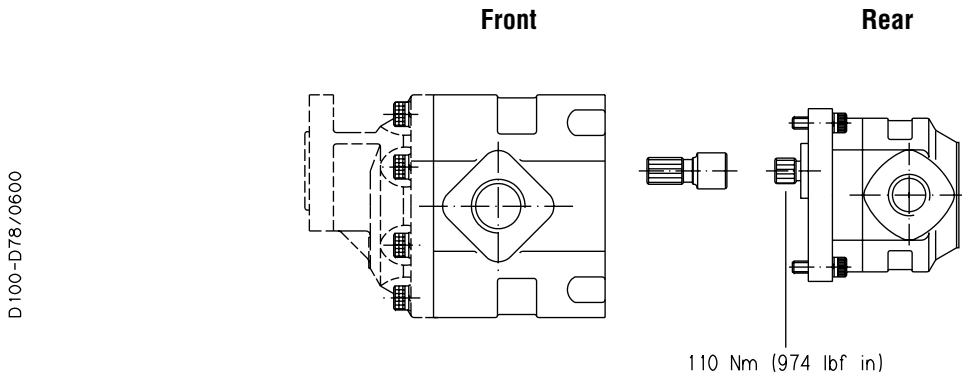

FORMULA 30 + POLARIS 20 STANDARD VERSION

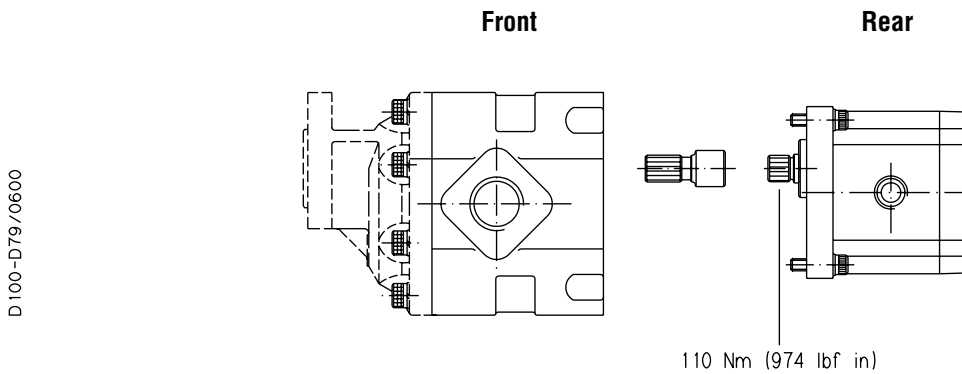

01/08.2005

FORMULA 30

MULTIPLE PUMPS SPECIAL COMBINATION

Special front section arranged to fit single pumps.
To order please consult our technical sales department.

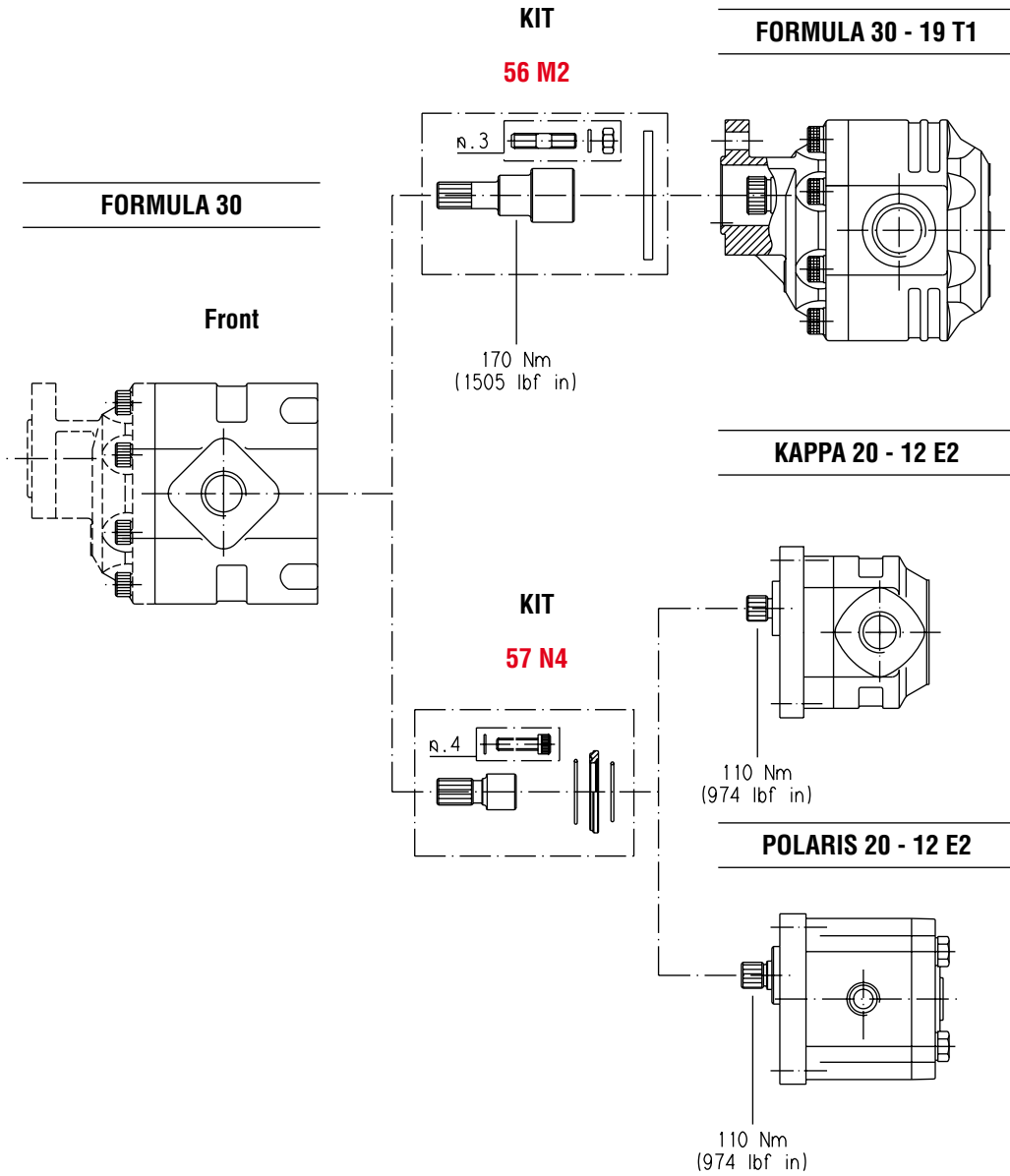

D100-110/1003

01/08.2005

FORMULA 30 END DRIVE SHAFT

ITALIAN STANDARD

19

ISO STANDARD

16

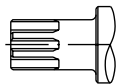

MAX 360 Nm (3186 lbf in)

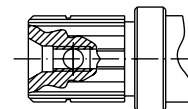

MAX 300 Nm (2655 lbf in)

FORMULA 40

MULTIPLE PUMPS COMBINATION

FORMULA 40 + FORMULA 40 STANDARD VERSION

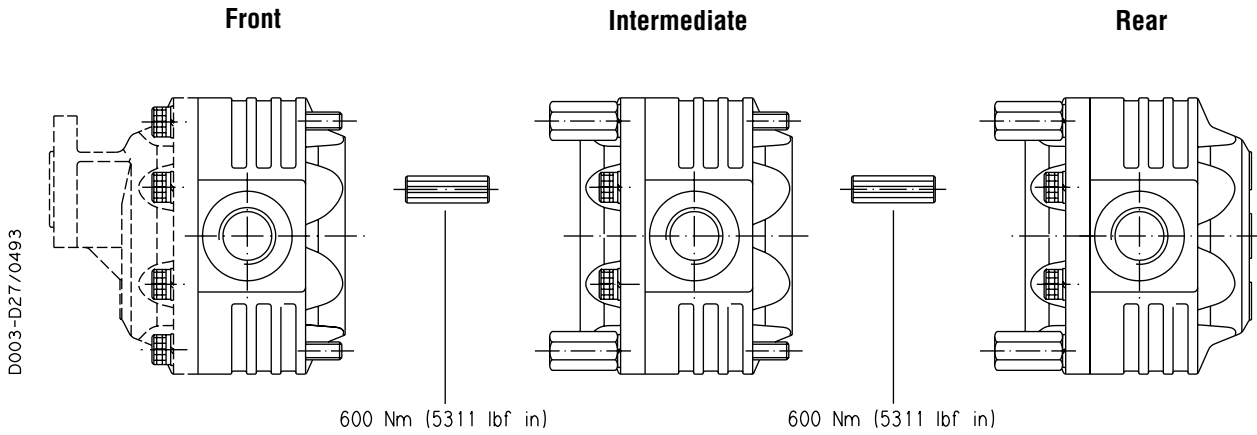

FORMULA 40 + FORMULA 30 STANDARD VERSION

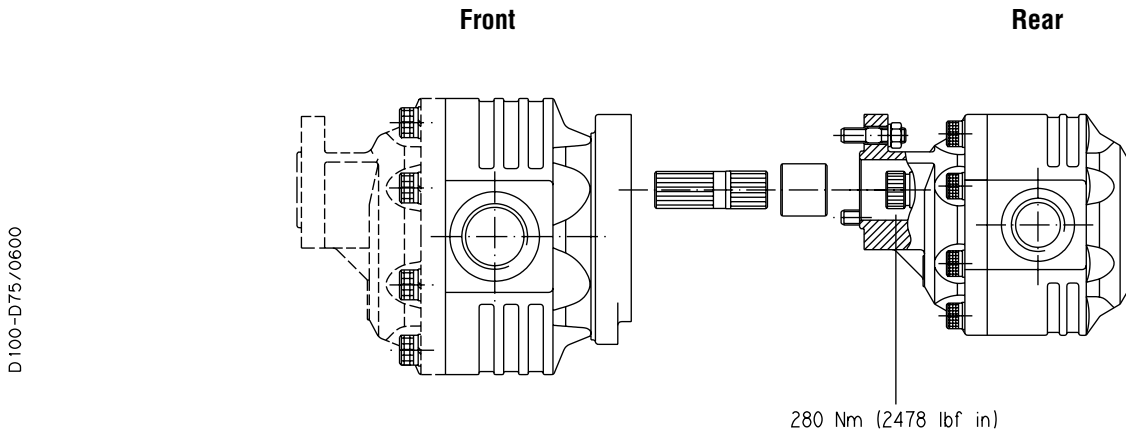

FORMULA 40 + FORMULA 20 STANDARD VERSION

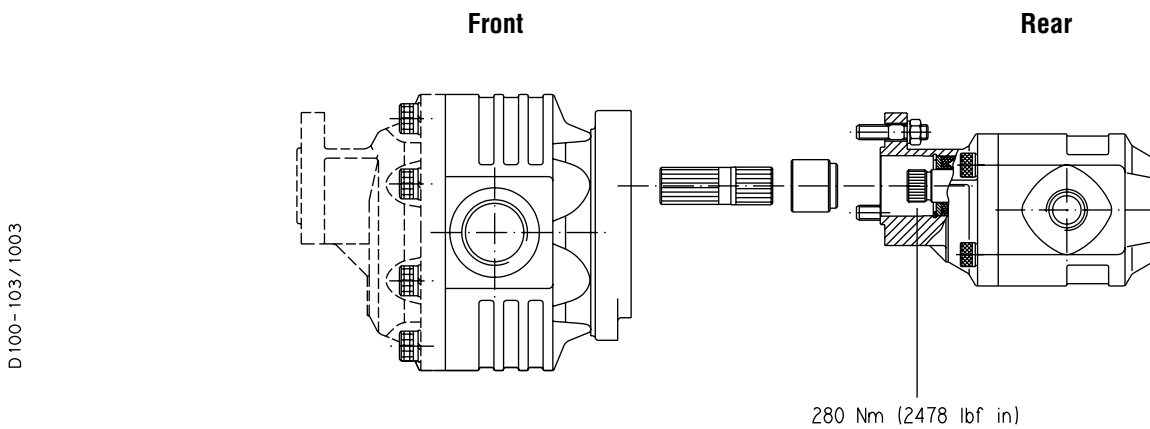

01/08.2005

FORMULA 40

MULTIPLE PUMPS COMBINATION

FORMULA 40 + KAPPA20

STANDARD VERSION

Front

Rear

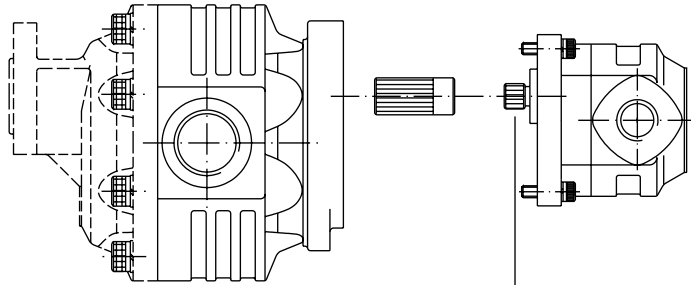

110 Nm (974 lbf in)

FORMULA 40 + POLARIS20

STANDARD VERSION

Front

Rear

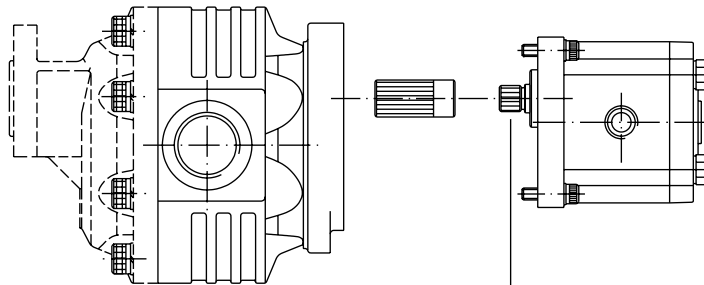

110 Nm (974 lbf in)

FORMULA 40 END DRIVE SHAFT

ITALIAN STANDARD

19

ISO STANDARD

16

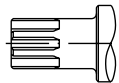

MAX 400 Nm (3540 lbf in)

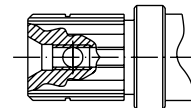

MAX 350 Nm (3098 lbf in)

SPLINE SAE STANDARD

06

STRAIGHT SAE STANDARD

34

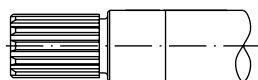

MAX 900 Nm (7965 lbf in)

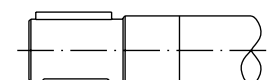

MAX 600 Nm (5310 lbf in)

01/08.2005

GAS STRAIGHT THREAD PORTS
British standard pipe parallel (55°) conforms to UNI - ISO 228

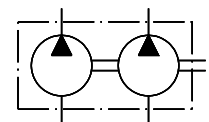
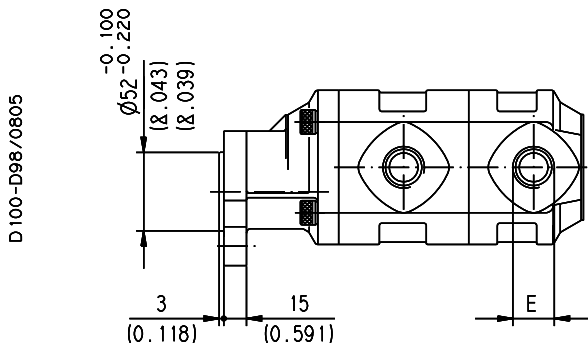
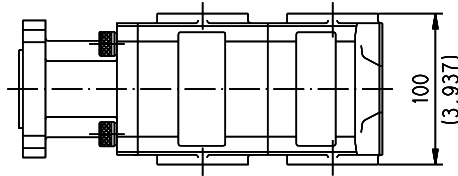
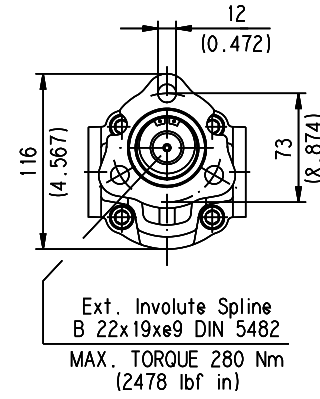
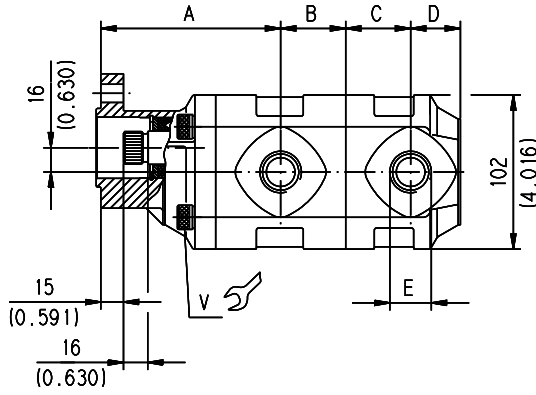

Screw tightening torque Nm (lbf in)

V

70 ± 7 (558 ÷ 682)

01/08.2005

| Pump type | A | B | C | D | E |
|-------------------|---------------|--------------|--------------|--------------|----------|
| | mm (in) | mm (in) | mm (in) | mm (in) | |
| FP 20•8 | 105 (4.272) | 37,5 (1.476) | 29 (1.142) | 27,5 (1.083) | G 1/2 |
| FP 20•11,2 | 108,5 (4.272) | 38,5 (1.516) | 32,5 (1.280) | 27,5 (1.083) | |
| FP 20•16 | 112,5 (4.429) | 43 (1.693) | 36,5 (1.437) | 32,5 (1.280) | |
| FP 20•20 | 119 (4.685) | 43 (1.693) | 43 (1.693) | 33 (1.299) | G 3/4 |
| FP 20•25 | 112 (4.409) | 58 (2.283) | 36 (1.417) | 48 (1.890) | |
| FP 20•31,5 | 122 (4.803) | 58 (2.283) | 46 (1.811) | 48 (1.890) | |

The length of a triple pump is obtained with the sum of the following dimensions: **A+B+C+B+C+D**.

How to order a triple pump

(for double pump omit the intermediate pump)

| Front pump | / | Intermediate pump | / | Rear pump | (1) Rotation | - | (2) Seals |
|------------------|---|-------------------|---|----------------|--------------|---|-----------|
| FP20•11,2 | / | 20•11,2 | / | 20•11,2 | S | - | |

(1) S= Left - D= Right

(2) See page 3 (for Buna N seals no code)

01/08.2005

FORMULA 30

HYDRAULIC GEAR PUMPS ITALIAN STANDARD

19 T

ISO (Z0) and SAE (S3) version available (◆)

GAS STRAIGHT THREAD PORTS
British standard pipe parallel (55°) conforms to UNI - ISO 228

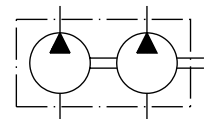
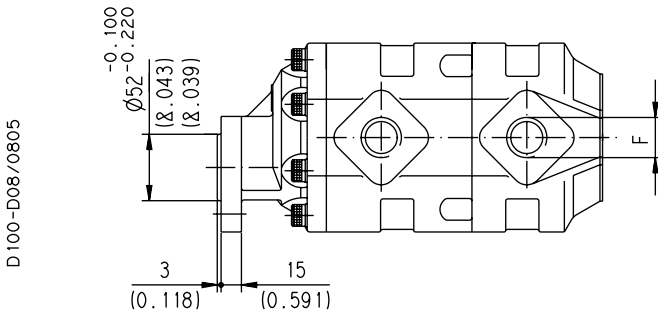
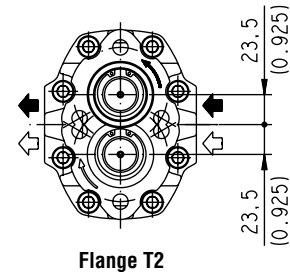
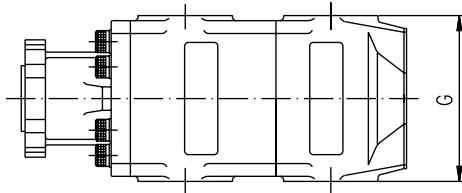
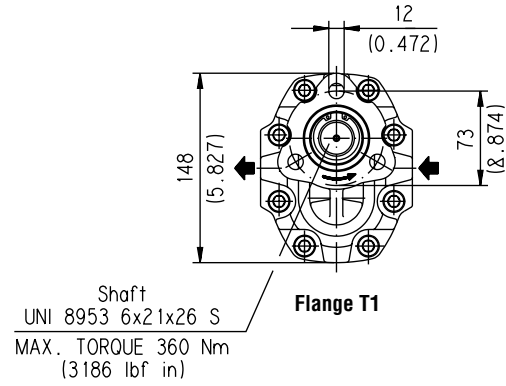
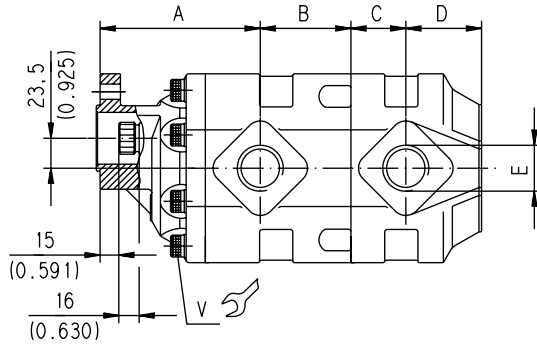

Screw tightening torque Nm (lbf in)

V

70 ±7 (558 ÷ 682)

01/08.2005

FORMULA 30
HYDRAULIC GEAR PUMPS ITALIAN STANDARD
19 T

(◆) Dimension "A"
 ISO and SAE version

mm (in)

| | |
|---------------|------------------------|
| A (Z0) | A (19 T) + 18 (0.709) |
| A (S3) | A (19 T) - 2,5 (0.098) |

| Pump type | A | B | C | D | E | F | G | Ports code | |
|---------------------|---------------|------------|------------|------------|----------|----------|-------------|-------------------|-----------|
| | (19 T) | | | | | | | IN | OUT |
| | mm (in) | mm (in) | mm (in) | mm (in) | IN | OUT | mm (in) | | |
| FP 30•17 | 111,5 (4.390) | 63 (2.480) | 29 (1.142) | 49 (1.929) | | | | | |
| FP 30•27 | 117,5 (4.626) | 63 (2.480) | 35 (1.378) | 49 (1.929) | | | | | |
| FP 30•34 | 122,5 (4.823) | 63(2.480) | 40 (1.575) | 49 (1.929) | G 3/4 | G 3/4 | 130 (5.118) | GE | GE |
| FP 30•38 | 125,5 (4.941) | 63(2.480) | 43 (1.693) | 49 (1.929) | | | | | |
| FP 30•43 | 128,5 (5.059) | 63 (2.480) | 46 (1.811) | 49 (1.929) | | | | | |
| FP 30•51 | 125,5 (4.941) | 71 (2.795) | 43 (1.693) | 57 (2.244) | | | | | |
| FP 30•61 | 132,5 (5.217) | 70 (2.756) | 50 (1.969) | 56 (2.205) | G 1 | | | GF | GF |
| FP 30•73 | 140,5 (5.531) | 70 (2.756) | 58 (2.283) | 56 (2.205) | | G 1 | 135 (5.315) | | |
| FP 30•82 (●) | 145,5 (5.728) | 70 (2.756) | --- | --- | G 1 1/4 | | | GG | |

(●) Available only for front and intermediate section.

The length of a triple pump is obtained with the sum of the following dimensions: **A+B+C+B+C+D**.

How to order a triple pump

(for double pump omit the intermediate pump)

| | | | | | | | |
|----------------|---|-------------------|---|--------------|--------------|---|-----------|
| Front pump | / | Intermediate pump | / | Rear pump | (1) Rotation | - | (2) Seals |
| FP30•17 | / | 30•17 | / | 30•17 | S | - | |

(1) S= Left - D= Right

(2) See page 3 (for Buna N seals no code)

01/08.2005

FORMULA 30

HYDRAULIC GEAR PUMPS ITALIAN STANDARD

19 T+KP20

ISO (Z0) and SAE (S3) version available (◆)

GAS STRAIGHT THREAD PORTS
British standard pipe parallel (55°) conforms to UNI - ISO 228

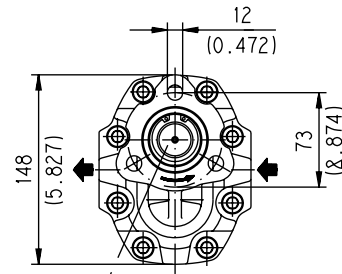
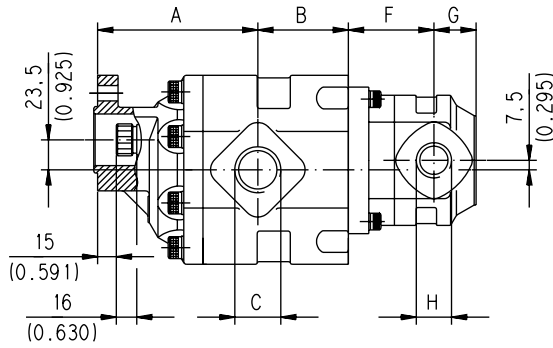

Shaft
UNI 8953 6x21x25 S
MAX. TORQUE 360 Nm
(3186 lbf in)

Flange T1

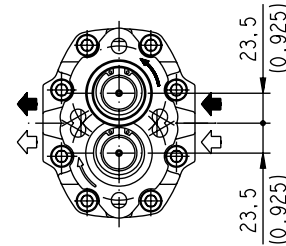
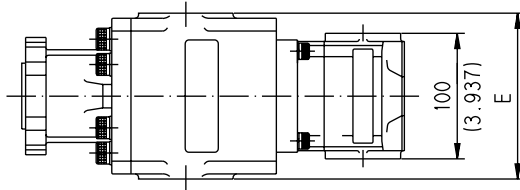

Flange T2

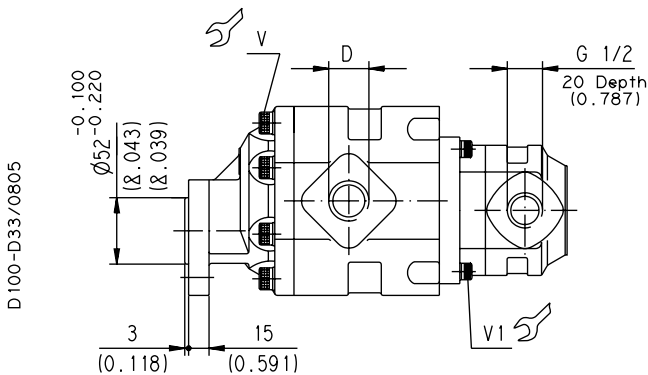

D100-D33/0805

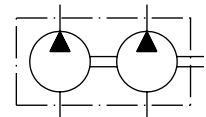

01/08.2005

Screw tightening torque Nm (lbf in)

| V | V1 |
|------------------------------|------------------------------|
| 70 ^{±7} (558 ÷ 682) | 70 ^{±7} (558 ÷ 682) |

FORMULA 30**HYDRAULIC GEAR PUMPS ITALIAN STANDARD****19 T+KP20**

(◆) Dimension "A"
 ISO and SAE version

mm (in)

A (Z0) A (19 T) + 18 (0.709)

A (S3) A (19 T) - 2,5 (0.098)

| Pump type | A | B | C | D | E | Ports code | |
|-----------------|---------------|------------|----------|----------|-------------|-------------------|-----------|
| | (19 T) | | | | | IN | OUT |
| | mm (in) | mm (in) | IN | OUT | mm (in) | | |
| FP 30•17 | 111,5 (4.390) | 63 (2.480) | | | | | |
| FP 30•27 | 117,5 (4.626) | 63 (2.480) | | | | | |
| FP 30•34 | 122,5 (4.823) | 63 (2.480) | G 3/4 | G 3/4 | 130 (5.118) | GE | GE |
| FP 30•38 | 125,5 (4.941) | 63 (2.480) | | | | | |
| FP 30•43 | 128,5 (5.059) | 63 (2.480) | | | | | |
| FP 30•51 | 125,5 (4.941) | 71 (2.795) | | | | | |
| FP 30•61 | 132,5 (5.217) | 70 (2.756) | G 1 | G 1 | | GF | GF |
| FP 30•73 | 140,5 (5.531) | 70 (2.756) | | | 135 (5.315) | | |
| FP 30•82 | 145,5 (5.728) | 70 (2.756) | G 1 1/4 | | | GG | |

| Pump type | F | G | H | Ports code | |
|-------------------|--------------|---------------|---------------------|-------------------|-----------|
| | mm (in) | mm (in) | IN | IN | OUT |
| KP 20•4 | 60 (2.362) | 27,5 (1.083) | | | |
| KP 20•6,3 | 62,5 (2.460) | 27,5 (1.083) | G 1/2 | GD | |
| KP 20•8 | 65 (2.559) | 27,5 (1.083)) | Depth 20 (0.787) | | |
| KP 20•11,2 | 68,5 (2.697) | 27,5 (1.083) | | | |
| KP 20•14 | 67 (2.638) | 33 (1.299) | | | GD |
| KP 20•16 | 72,5 (2.854) | 33 (1.299) | G 3/4 | GE | |
| KP 20•20 | 79 (3.110) | 33 (1.299) | Depth 22 (0.866) | | |
| KP 20•25 | 72 (2.835) | 48 (1.890) | | | |
| KP 20•31,5 | 82 (3.228) | 48 (1.890) | | | |

01/08.2005

How to order

| Front pump/ | / | Rear pump | - | Ports position | Ports IN/OUT | (1) Rotation | (2) Seals |
|----------------|----------|-----------|----------|----------------|--------------|--------------|--------------|
| FP30•17 | - | 67 | / | KP20•4 | - | L | GD/GD |
| | | | | | | S | - |

(1) S= Left - D= Right

(2) See page 3 (for Buna N seals no code)

FORMULA 30

HYDRAULIC GEAR PUMPS ITALIAN STANDARD

19 T+PL20

ISO (Z0) and SAE (S3) version available (◆)

GAS STRAIGHT THREAD PORTS
British standard pipe parallel (55°) conforms to UNI - ISO 228

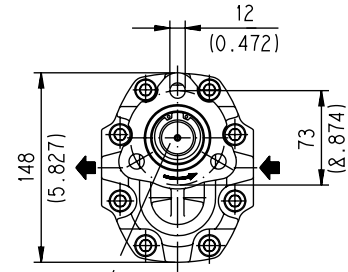
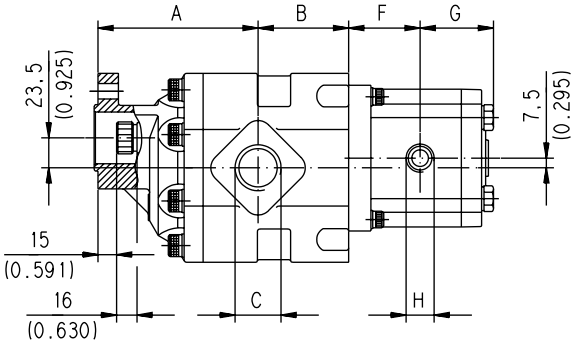

Shaft
UNI 8953 6x21x25 S
MAX. TORQUE 360 Nm
(3186 lbf in)

Flange T1

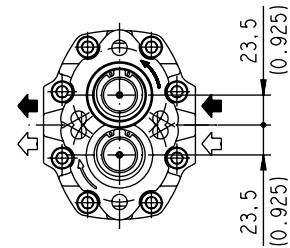
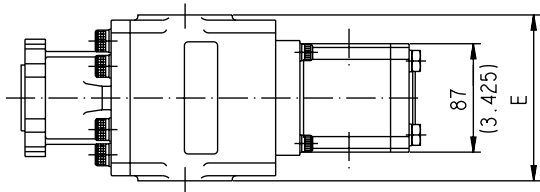

Flange T2

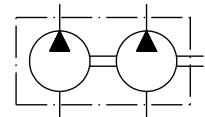
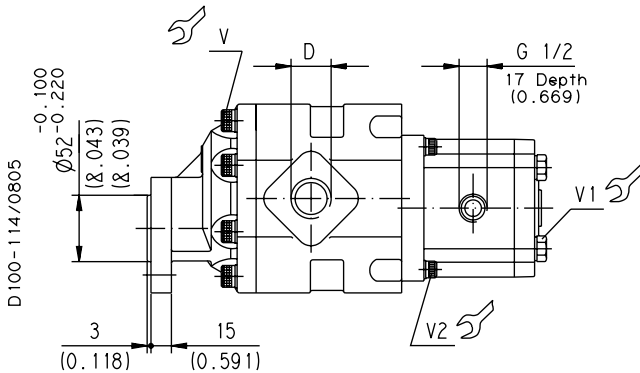

Screw tightening torque Nm (lbf in)

| V | V1 (●) | V2 |
|-------------------|-------------------|-------------------|
| 70 ±7 (558 ÷ 682) | 70 ±7 (558 ÷ 682) | 70 ±7 (558 ÷ 682) |

(●) With cast iron front cover

01/08.2005

FORMULA 30**HYDRAULIC GEAR PUMPS ITALIAN STANDARD****19 T+PL20**

(◆) Dimension "A"
 ISO and SAE version

mm (in)

A (Z0) A (19 T) + 18 (0.709)

A (S3) A (19 T) - 2,5 (0.098)

| Pump type | A (19 T) | B | C | D | E | Ports code | |
|-----------------|--------------------|------------|----------|----------|-------------|-------------------|-----------|
| | mm (in) | mm (in) | IN | OUT | mm (in) | IN | OUT |
| FP 30•17 | 111,5 (4.390) | 63 (2.480) | | | | | |
| FP 30•27 | 117,5 (4.626) | 63 (2.480) | | | | | |
| FP 30•34 | 122,5 (4.823) | 63 (2.480) | G 3/4 | G 3/4 | 130 (5.118) | GE | GE |
| FP 30•38 | 125,5 (4.941) | 63 (2.480) | | | | | |
| FP 30•43 | 128,5 (5.059) | 63 (2.480) | | | | | |
| FP 30•51 | 125,5 (4.941) | 71 (2.795) | | | | | |
| FP 30•61 | 132,5 (5.217) | 70 (2.756) | G 1 | G 1 | 135 (5.315) | GF | GF |
| FP 30•73 | 140,5 (5.531) | 70 (2.756) | | | | | |
| FP 30•82 | 145,5 (5.728) | 70 (2.756) | G 1 1/4 | | | GG | |

| Pump type | F | G | H | Ports code | |
|--------------------|--------------|--------------|---------------------|-------------------|-----------|
| | mm (in) | mm (in) | IN | IN | OUT |
| PLP 20•4 | 43,8 (1.722) | 49,3 (1.941) | | | |
| PLP 20•6,3 | 45 (1.772) | 50,5 (1.988) | | | |
| PLP 20•7,2 | 45,5 (1.791) | 51 (2.008) | | | |
| PLP 20•8 | 46,3 (1.821) | 51,8 (2.039) | G 1/2 | GD | |
| PLP 20•9 | 46,9 (1.846) | 52,4 (2.063) | Depth 17 (0.669) | | |
| PLP 20•10,5 | 48,3 (1.900) | 53,8 (2.118) | | | |
| PLP 20•11,2 | 48,5 (1.909) | 54 (2.126) | | | |
| PLP 20•14 | 51 (2.008) | 56,5 (2.224) | | | GD |
| PLP 20•16 | 52,8 (2.077) | 58,3 (2.295) | | | |
| PLP 20•19 | 54,5 (2.146) | 60 (2.553) | | | |
| PLP 20•20 | 56 (2.205) | 61,5 (2.421) | G 3/4 | GE | |
| PLP 20•24,5 | 58,8 (2.315) | 64,3 (2.531) | Depth 18 (0.709) | | |
| PLP 20•25 | 60 (2.362) | 65,5 (2.579) | | | |
| PLP 20•27,5 | 61,4 (2.417) | 66,9 (2.634) | | | |
| PLP 20•31,5 | 65 (2.559) | 70,5 (2.776) | | | |

How to order

| | | | | | | | | |
|----------------|----------|-----------|----------|----------------|--------------|--------------|--------------|-----------|
| Front pump/ | / | Rear pump | - | Ports position | Ports IN/OUT | (1) Rotation | - | (2) Seals |
| FP30•17 | - | 67 | / | PLP20•4 | - | L | GD/GD | S |

(1) S= Left - D= Right

(2) See page 3 (for Buna N seals no code)

01/08.2005

FORMULA 40

HYDRAULIC GEAR PUMPS ITALIAN STANDARD

19 T

ISO (Z0) version available (◆).
SAE (S8) version at page 62.

GAS STRAIGHT THREAD PORTS
British standard pipe parallel (55°) conforms to UNI - ISO 228

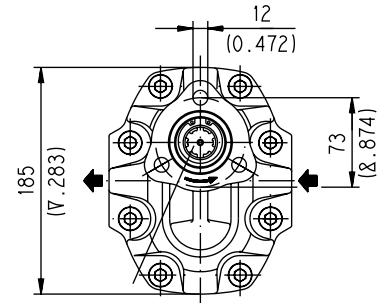
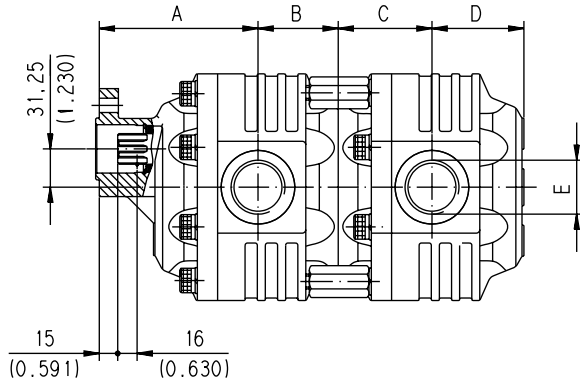

Shaft
UNI 8953 6x21x25 S
MAX. TORQUE 400 Nm
(3540 lbf in)

Flange T1

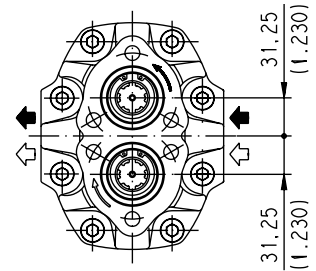
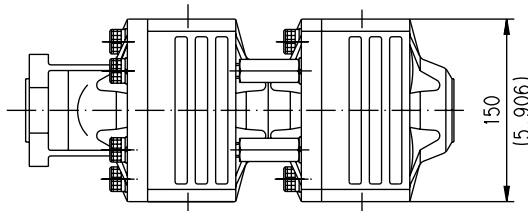

Flange T2

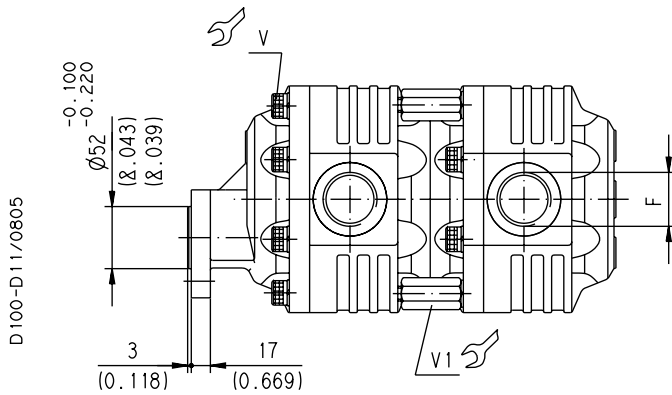

Screw tightening torque Nm (lbf in)

| V | V1 |
|---------------------|---------------------|
| 100 ±10 (797 ÷ 974) | 100 ±10 (797 ÷ 974) |

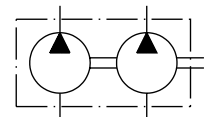

01/08.2005

(◆) Dimension "A"
 ISO version

mm (in)

A (Z0) A (19 T) + 11,5 (0.453)

| Pump type | A | B | C | D | E | F | Ports code | |
|------------------|---------------|--------------|--------------|------------|----------|----------|-------------------|-----------|
| | (19 T) | | | | | | IN | OUT |
| | mm (in) | mm (in) | mm (in) | mm (in) | IN | OUT | | |
| FP 40•63 | 119,5 (4.705) | 57,5 (2.264) | 65,5 (2.579) | 68 (2.677) | G 1 | G 3/4 | GF | GE |
| FP 40•73 | 123,5 (4.862) | 57,5 (2.264) | 69,5 (2.736) | 68 (2.677) | | | | |
| FP 40•87 | 128,5 (5.059) | 57,5 (2.264) | 74,5 (2.933) | 68 (2.677) | G 1 1/4 | G 1 | GG | GF |
| FP 40•109 | 129,5 (5.098) | 64,5 (2.539) | 75,5 (2.972) | 75 (2.953) | | | | |
| FP 40•133 | 138,5 (5.453) | 64,5 (2.539) | 84,5 (3.327) | 75 (2.953) | G 1 1/2 | | GH | |
| FP 40•151 | 144,5 (5.689) | 64,5 (2.539) | 90,5 (3.563) | 75 (2.953) | | | | |

The length of a triple pump is obtained with the sum of the following dimensions: **A+B+C+B+C+D**.

How to order a triple pump

(for double pump omit the intermediate pump)

| | | | | | | | |
|----------------|---|-------------------|---|--------------|--------------|---|-----------|
| Front pump | / | Intermediate pump | / | Rear pump | (1) Rotation | - | (2) Seals |
| FP40•63 | / | 40•63 | / | 40•63 | S | - | |

(1) S= Left - D= Right

(2) See page 3 (for Buna N seals no code)

01/08.2005

ISO (Z0) and SAE (S8) version available (◆)

GAS STRAIGHT THREAD PORTS
British standard pipe parallel (55°) conforms to UNI - ISO 228

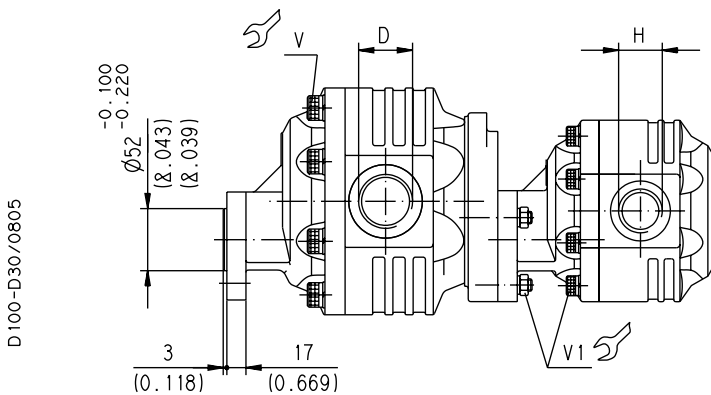
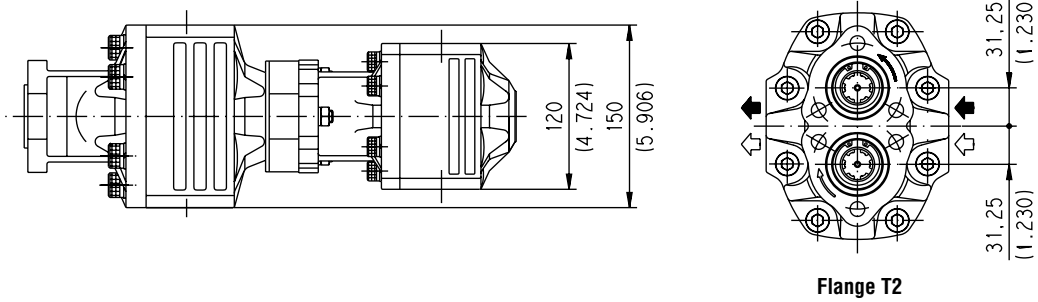
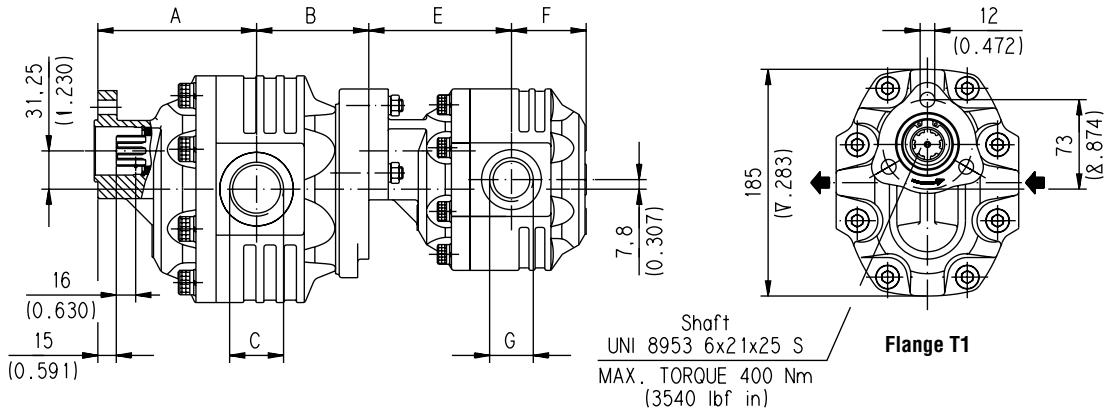

Screw tightening torque Nm (lbf in)

| V | V1 |
|--------------------------------|------------------------------|
| 100 ⁺¹⁰ (797 ÷ 974) | 70 ⁺⁷ (558 ÷ 682) |

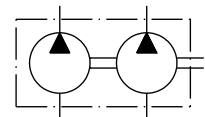

01/08.2005

FORMULA 40
HYDRAULIC GEAR PUMPS ITALIAN STANDARD
19 T+FP30

(◆) Dimension "A"
 ISO and SAE version

mm (in)

| | |
|---------------|-------------------------|
| A (Z0) | A (19 T) + 11,5 (0.453) |
| A (S8) | A (19 T) + 1 (0.039) |

| Pump type | A | B | C | D | Ports code | |
|------------------|---------------|--------------|----------|----------|-------------------|-----------|
| | (19 T) | | | | IN | OUT |
| | mm (in) | mm (in) | IN | OUT | IN | OUT |
| FP 40•63 | 119,5 (4.705) | 84,5 (3.327) | G 1 | G 3/4 | GF | GE |
| FP 40•73 | 123,5 (4.862) | 84,5 (3.327) | | | | |
| FP 40•87 | 128,5 (5.059) | 84,5 (3.327) | G 1 1/4 | | GG | |
| FP 40•109 | 129,5 (5.098) | 91,5 (3.602) | | G 1 | | GF |
| FP 40•133 | 138,5 (5.453) | 91,5 (3.602) | G 1 1/2 | | GH | |
| FP 40•151 | 144,5 (5.689) | 91,5 (3.602) | | | | |

| Pump type | E | F | G | H |
|-----------------|---------------|------------|----------|----------|
| | mm (in) | | | |
| FP 30•17 | 100,5 (5.925) | 50 (1.969) | G 1/2 | G 1/2 |
| FP 30•27 | 106,5 (4.193) | 50 (1.969) | | |
| FP 30•34 | 106,5 (4.193) | 55 (2.165) | G 3/4 | G 3/4 |
| FP 30•38 | 109,5 (4.311) | 55 (2.165) | | |
| FP 30•43 | 112,5 (4.429) | 55 (2.165) | | |
| FP 30•51 | 110,5 (4.350) | 62 (2.441) | | |
| FP 30•61 | 116,5 (4.587) | 62 (2.441) | G 1 | G 1 |
| FP 30•73 | 117,5 (4.623) | 69 (2.717) | | |
| FP 30•82 | 122,5 (4.823) | 69 (2.717) | G 1 1/4 | |

01/08.2005

How to order

| | | | | | |
|----------------|---|-----------|--------------|----------------|-----------|
| Front pump | / | Rear pump | (1) Rotation | - | (2) Seals |
| FP40•63 | - | 53 | / | FP30•17 | S |
| | | | | | - |

(1) S= Left - D= Right

(2) See page 3 (for Buna N seals no code)

ISO (Z0) and SAE (S8) version available (◆)

GAS STRAIGHT THREAD PORTS
British standard pipe parallel (55°) conforms to UNI - ISO 228

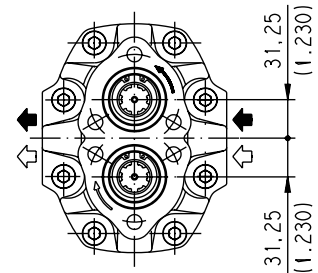
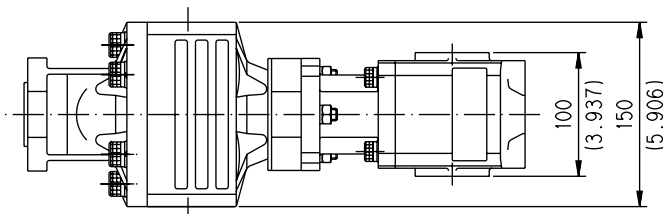
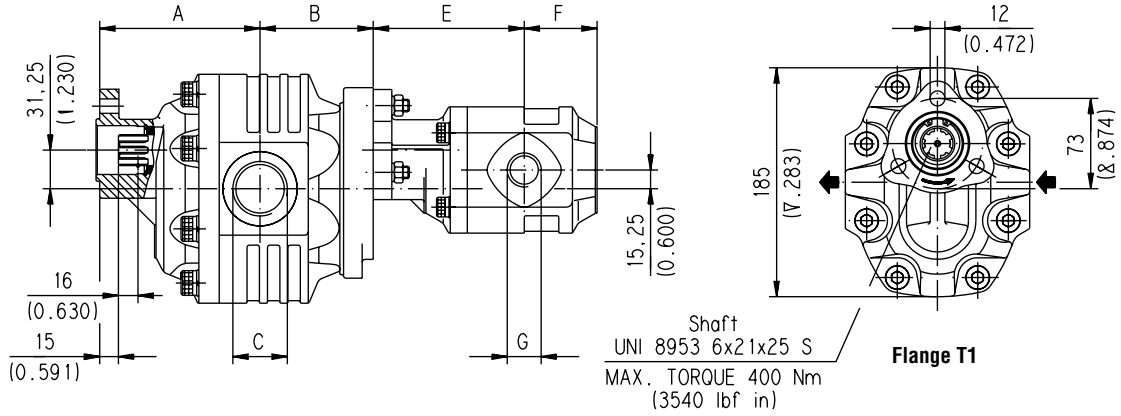

Flange T2

D100-D96/0805

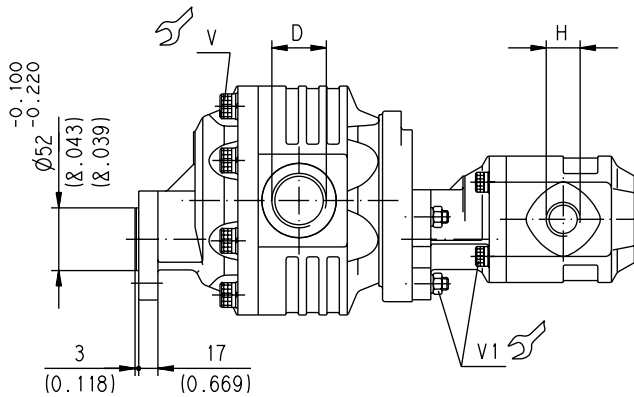

Screw tightening torque Nm (lbf in)

| V | V1 |
|--------------------------------|------------------------------|
| 100 ⁺¹⁰ (797 ÷ 974) | 70 ⁺⁷ (558 ÷ 682) |

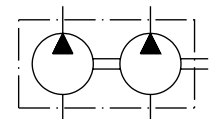

01/08.2005

FORMULA 40
HYDRAULIC GEAR PUMPS ITALIAN STANDARD
19 T+FP20

(◆) Dimension "A"
 ISO and SAE version

mm (in)

| | |
|---------------|-------------------------|
| A (Z0) | A (19 T) + 11,5 (0.453) |
| A (S8) | A (19 T) + 1 (0.039) |

| Pump type | A | B | C | D | Ports code | |
|------------------|---------------|--------------|----------|----------|-------------------|-----------|
| | (19 T) | | | | IN | OUT |
| | mm (in) | mm (in) | IN | OUT | | |
| FP 40•63 | 119,5 (4.705) | 84,5 (3.327) | G 1 | G 3/4 | GF | GE |
| FP 40•73 | 123,5 (4.862) | 84,5 (3.327) | | | | |
| FP 40•87 | 128,5 (5.059) | 84,5 (3.327) | G 1 1/4 | | GG | |
| FP 40•109 | 129,5 (5.098) | 91,5 (3.602) | | G 1 | | GF |
| FP 40•133 | 138,5 (5.453) | 91,5 (3.602) | G 1 1/2 | | GH | |
| FP 40•151 | 144,5 (5.689) | 91,5 (3.602) | | | | |

| Pump type | E | F | G | H |
|-------------------|---------------|--------------|----------|----------|
| | mm (in) | mm (in) | IN | IN |
| FP 20•8 | 105 (4.134) | 27,5 (1.083) | | |
| FP 20•11,2 | 108,5 (4.272) | 27,5 (1.083) | | |
| FP 20•16 | 112,5 (4.429) | 33 (1.299) | G 1/2 | G 1/2 |
| FP 20•20 | 119 (4.685) | 33 (1.299) | | |
| FP 20•25 | 112 (4.409) | 48 (1.890) | | |
| FP 20•31,5 | 122 (4.803) | 48 (1.890) | | |
| FP 20•36 | 116,5 (4.587) | 59 (2.323) | G 3/4 | G 3/4 |
| FP 20•40 | 122 (4.803) | 59 (2.323) | | |

01/08.2005

How to order

| | | | | | |
|----------------|---|-----------|--------------|------------------|------------|
| Front pump | / | Rear pump | (1) Rotation | - | (2) Seals |
| FP40•63 | - | 54 | / | FP20•11,2 | S - |

(1) S= Left - D= Right

(2) See page 3 (for Buna N seals no code)

FORMULA 40

HYDRAULIC GEAR PUMPS ITALIAN STANDARD

19 T+KP20

ISO (Z0) and SAE (S8) version available (◆)

GAS STRAIGHT THREAD PORTS
British standard pipe parallel (55°) conforms to UNI - ISO 228

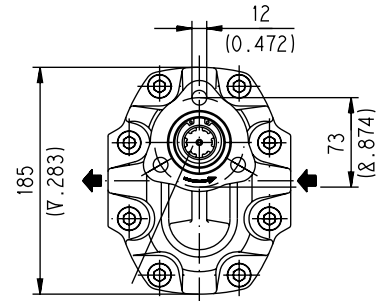
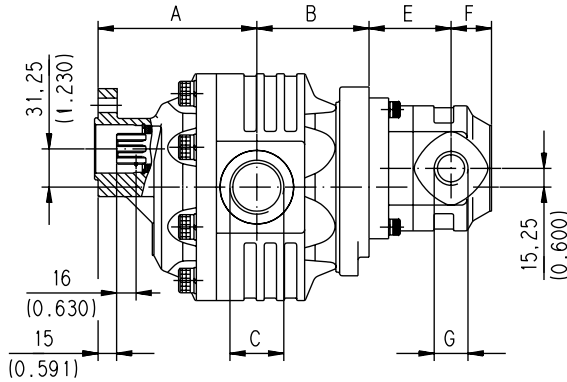

Shaft
UNI 8953 6x21x25 S
MAX. TORQUE 400 Nm
(3540 lbf in)

Flange T1

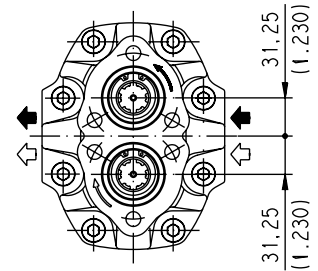
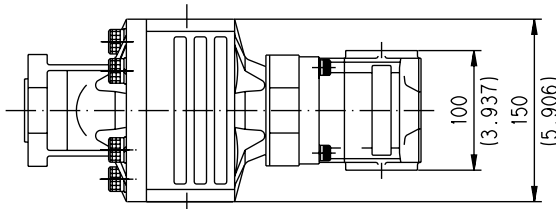

Flange T2

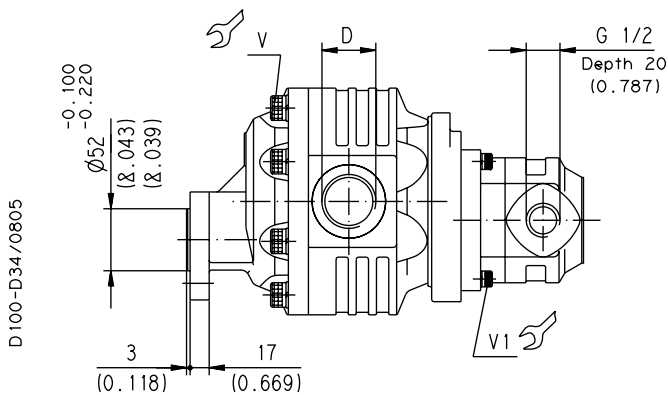

D100-D34/0805

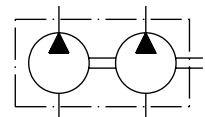

Screw tightening torque Nm (lbf in)

| V | V1 |
|--------------------------------|------------------------------|
| 100 ⁺¹⁰ (797 ÷ 974) | 70 ⁺⁷ (558 ÷ 682) |

01/08.2005

FORMULA 40
HYDRAULIC GEAR PUMPS ITALIAN STANDARD
19 T+KP20

(◆) Dimension "A"
ISO and SAE version

mm (in)

| | |
|---------------|-------------------------|
| A (Z0) | A (19 T) + 11,5 (0.453) |
| A (S8) | A (19 T) + 1 (0.039) |

| Pump type | A (19 T) | B | C | D | Ports code | |
|------------------|--------------------|--------------|----------|----------|-------------------|-----------|
| | mm (in) | mm (in) | IN | OUT | IN | OUT |
| FP 40•63 | 119,5 (4.705) | 84,5 (3.327) | G 1 | G 3/4 | GF | GE |
| FP 40•73 | 123,5 (4.862) | 84,5 (3.327) | | | | |
| FP 40•87 | 128,5 (5.059) | 84,5 (3.327) | G 1 1/4 | G 1 | GG | GF |
| FP 40•109 | 129,5 (5.098) | 91,5 (3.602) | | | | |
| FP 40•133 | 138,5 (5.453) | 91,5 (3.602) | G 1 1/2 | | GH | |
| FP 40•151 | 144,5 (5.689) | 91,5 (3.602) | | | | |

| Pump type | F | G | H | Ports code | |
|-------------------|--------------|--------------|------------------------------|-------------------|-----------|
| | mm (in) | mm (in) | IN | IN | OUT |
| KP 20•4 | 60 (2.362) | 27,5 (1.083) | G 1/2 Depth 20 (0.787) | GD | |
| KP 20•6,3 | 62,5 (2.460) | 27,5 (1.083) | | | |
| KP 20•8 | 65 (2.559) | 27,5 (1.083) | | | |
| KP 20•11,2 | 68,5 (2.697) | 27,5 (1.083) | G 3/4 Depth 22 (0.866) | GE | GD |
| KP 20•14 | 67 (2.638) | 33 (1.299) | | | |
| KP 20•16 | 72,5 (2.854) | 33 (1.299) | | | |
| KP 20•20 | 79 (3.110) | 33 (1.299) | | | |
| KP 20•25 | 72 (2.835) | 48 (1.890) | | | |
| KP 20•31,5 | 82 (3.228) | 48 (1.890) | | | |

01/08.2005

How to order

| | | | | | | | | | |
|----------------|----------|-----------|----------|----------------|--------------|--------------|--------------|-----------|----------|
| Front pump | / | Rear pump | - | Ports position | Ports IN/OUT | (1) Rotation | - | (2) Seals | |
| FP40•63 | - | 52 | / | KP20•4 | - | L | GD/GD | S | - |

(1) S= Left - D= Right

(2) See page 3 (for Buna N seals no code)

FORMULA 40

HYDRAULIC GEAR PUMPS ITALIAN STANDARD

19 T+PL20

ISO (Z0) and SAE (S8) version available (◆)

GAS STRAIGHT THREAD PORTS
British standard pipe parallel (55°) conforms to UNI - ISO 228

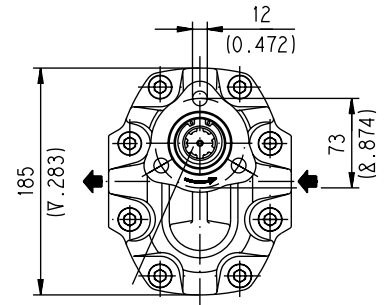
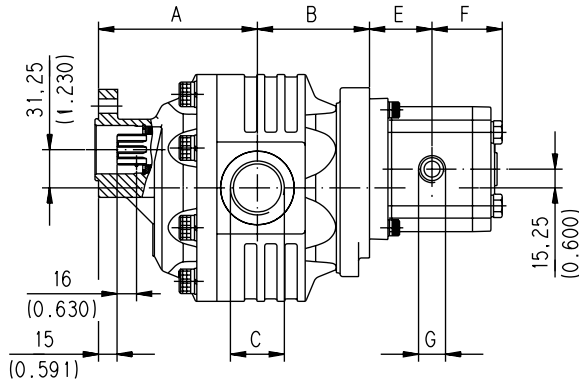

Shaft
UNI 8953 6x21x25 S
MAX. TORQUE 400 Nm
(3540 lbf in)

Flange T1

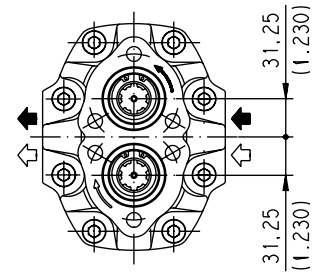
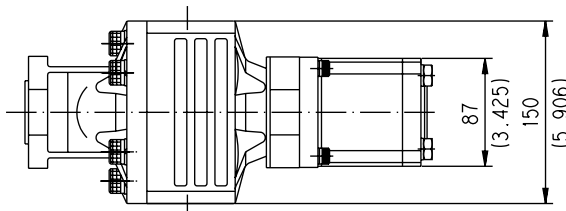

Flange T2

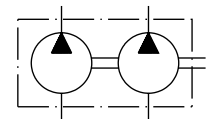
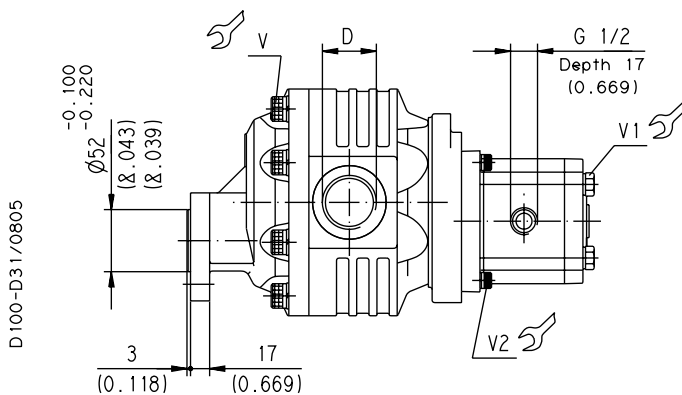

Screw tightening torque Nm (lbf in)

| V | V1 (●) | V2 |
|---------------------|-------------------|-------------------|
| 100 ±10 (797 ÷ 974) | 70 ±7 (558 ÷ 682) | 70 ±7 (558 ÷ 682) |

(●) With cast iron front cover.

01/08.2005

FORMULA 40
POMPE A INGRANAGGI UNIFICAZIONE ITALIANA
19 T+PL20

(◆) Dimension "A"
 ISO and SAE version

mm (in)

A (Z0) A (19 T) + 11,5 (0.453)

A (S8) A (19 T) + 1 (0.039)

| Pump type | A | B | C | D | Ports code | |
|------------------|---------------|--------------|----------|----------|-------------------|-----------|
| | (19 T) | | | | IN | OUT |
| | mm (in) | mm (in) | IN | OUT | | |
| FP 40•63 | 119,5 (4.705) | 84,5 (3.327) | G 1 | G 3/4 | GF | GE |
| FP 40•73 | 123,5 (4.862) | 84,5 (3.327) | | | | |
| FP 40•87 | 128,5 (5.059) | 84,5 (3.327) | G 1 1/4 | | GG | |
| FP 40•109 | 129,5 (5.098) | 91,5 (3.602) | | G 1 | | GF |
| FP 40•133 | 138,5 (5.453) | 91,5 (3.602) | G 1 1/2 | | GH | |
| FP 40•151 | 144,5 (5.689) | 91,5 (3.602) | | | | |

| Pump type | E | F | G | Ports code | |
|--------------------|--------------|--------------|----------|-------------------|-----------|
| | mm (in) | mm (in) | mm (in) | IN | OUT |
| PLP 20•4 | 43,8 (1.722) | 49,3 (1.941) | | | |
| PLP 20•6,3 | 45 (1.772) | 50,5 (1.988) | | | |
| PLP 20•7,2 | 45,5 (1.791) | 51 (2.008) | G 1/2 | GD | |
| PLP 20•8 | 46,3 (1.821) | 51,8 (2.039) | Depth 17 | | |
| PLP 20•9 | 46,9 (1.846) | 52,4 (2.063) | (0.669) | | |
| PLP 20•10,5 | 48,3 (1.900) | 53,8 (2.118) | | | |
| PLP 20•11,2 | 48,5 (1.909) | 54 (2.126) | | | |
| PLP 20•14 | 51 (2.008) | 56,5 (2.224) | | | GD |
| PLP 20•16 | 52,8 (2.077) | 58,3 (2.295) | | | |
| PLP 20•19 | 54,5 (2.146) | 60 (2.553) | | | |
| PLP 20•20 | 56 (2.205) | 61,5 (2.421) | G 3/4 | GE | |
| PLP 20•24,5 | 58,8 (2.315) | 64,3 (2.531) | Depth 18 | | |
| PLP 20•25 | 60 (2.362) | 65,5 (2.579) | (0.709) | | |
| PLP 20•27,5 | 61,4 (2.417) | 66,9 (2.634) | | | |
| PLP 20•31,5 | 65 (2.559) | 70,5 (2.776) | | | |

01/08.2005

How to order

| | | | | | | | | | |
|----------------|----------|-----------|----------|----------------|--------------|--------------|--------------|-----------|----------|
| Front pump/ | / | Rear pump | - | Ports position | Ports IN/OUT | (1) Rotation | - | (2) Seals | |
| FP40•63 | - | 52 | / | PLP20•4 | - | L | GD/GD | S | - |

(1) S= Left - D= Right

(2) See page 3 (for Buna N seals no code)

FORMULA 40

HYDRAULIC GEAR PUMPS SAE STANDARD

SAE

SAE STRAIGHT THREAD PORTS J514
American straight thread UNC-UNF 60° conforms to ANSI B 1.1

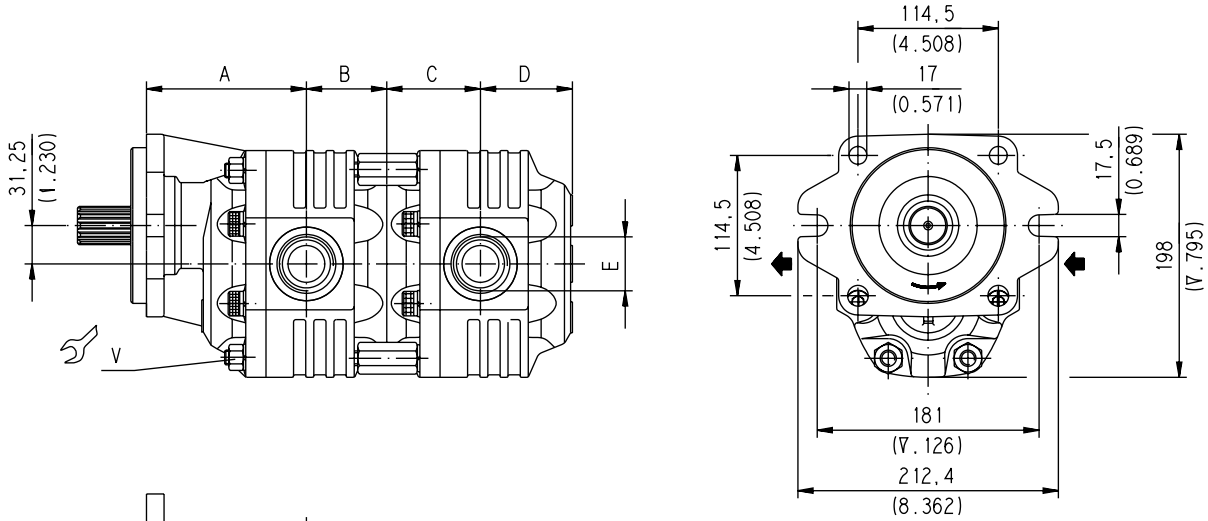

D 100-D.12/0805

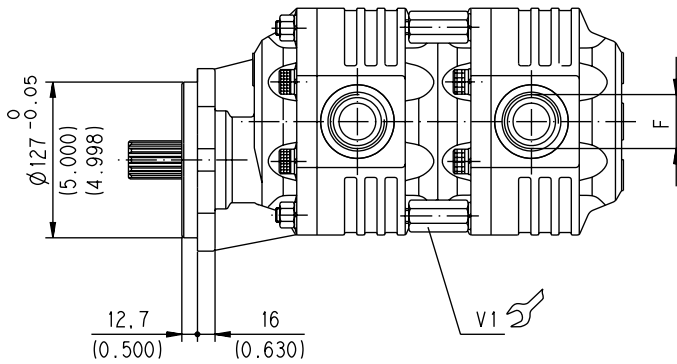
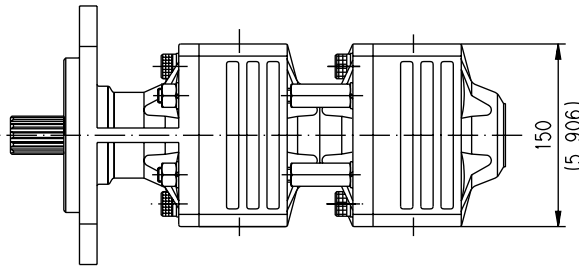

| Screw tightening torque Nm (lbf in) | |
|-------------------------------------|---------------------|
| V | V1 |
| 100 ±10 (797 ÷ 974) | 100 ±10 (797 ÷ 974) |

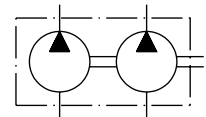

| Pump type | A | B | C | D | E | F | Ports code | |
|------------------|---------------|--------------|--------------|------------|-----------------|-----------------|------------|-----------|
| | mm (in) | mm (in) | mm (in) | mm (in) | IN | OUT | IN | OUT |
| FP 40•63 | 120,5 (4.744) | 57,5 (2.264) | 65,5 (2.579) | 68 (2.677) | 1-5/16-12 UN-2B | 1-1/16-12 UN-2B | OF | OD |
| FP 40•73 | 124,5 (4.902) | 57,5 (2.264) | 69,5 (2.736) | 68 (2.677) | | | | |
| FP 40•87 | 129,5 (5.098) | 57,5 (2.264) | 74,5 (2.933) | 68 (2.677) | 1-5/8-12 UN-2B | 1-5/16-12 UN-2B | OG | OF |
| FP 40•109 | 130,5 (5.138) | 64,5 (2.539) | 75,5 (2.972) | 75 (2.953) | | | | |
| FP 40•133 | 139,5 (5.492) | 64,5 (2.539) | 84,5 (3.327) | 75 (2.953) | 1-7/8-12 UN-2B | | OH | |
| FP 40•151 | 145,5 (5.728) | 64,5 (2.539) | 90,5 (3.563) | 75 (2.953) | | | | |

The length of a triple pump is obtained with the sum of the following dimensions: **A+B+C+B+C+D**.

01/08.2005

FORMULA 40 SAE VERSION

SAE

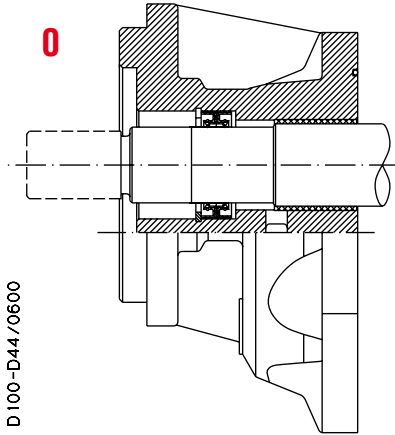

Version for applications without radial and axial load on the drive shaft.

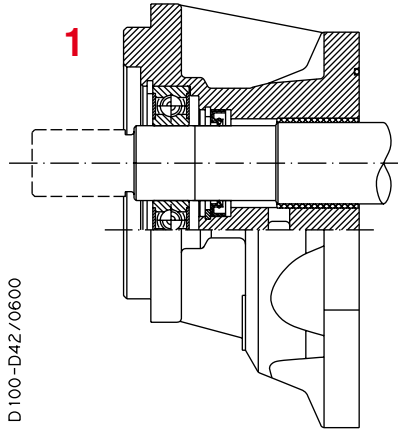

Version for applications with low radial load and without axial load on the drive shaft

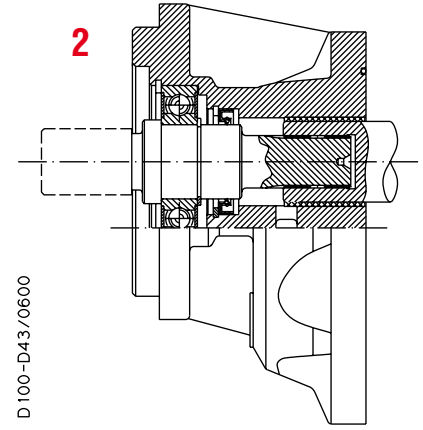

Special version with independent shaft for applications with low radial load and without axial load on the drive shaft.

FORMULA 40 SAE END DRIVE SHAFT

SAE

SAE "C" SPLINE

06

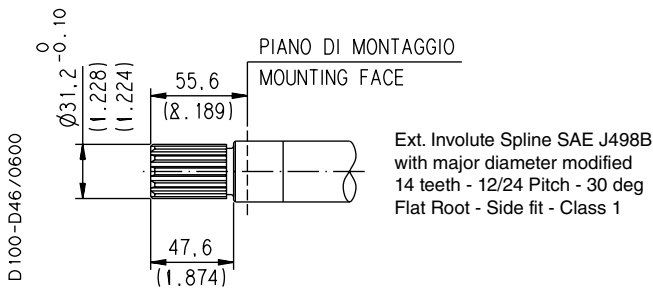

MAX 900 Nm (7966 lbf in) ◆

SAE "C" STRAIGHT

34

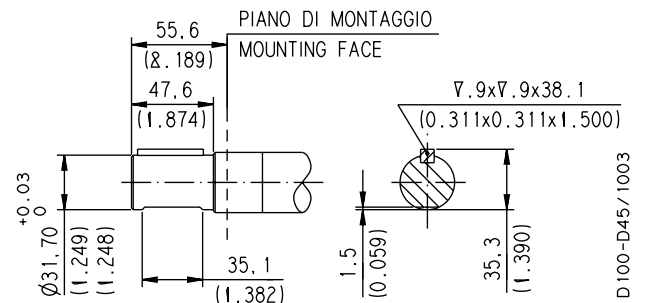

MAX 600 Nm (5311 lbf in) ◆

◆For "2" version whichever and shsft, the max. torque applicable is M= 600 Nm (5311 lbf in)

01/08.2005

PUMP - VERSION - SHAFT AVAILABILITY TABLE

SAE

| Pump type | VERSION | | | SHAFT |
|-------------|---------|---------|---------|-------|
| | 0 | 1 | 2 | |
| FP 40 • 63 | 06 | 06 | 06 - 34 | |
| FP 40 • 73 | 06 - 34 | 06 - 34 | 06 - 34 | |
| FP 40 • 87 | 06 - 34 | 06 - 34 | 06 - 34 | |
| FP 40 • 109 | 06 | 06 | 06 - 34 | |
| FP 40 • 133 | 06 - 34 | 06 - 34 | 06 - 34 | |
| FP 40 • 151 | 06 - 34 | 06 - 34 | 06 - 34 | |

HOW TO ORDER MULTIPLE PUMPS

| | | | | | | | |
|--------------------------|---|-----------|-----------|--------------|----------|--------------|----------|
| 1 | 2 | 3 | 4 | 5 | 6 | 7 | 8 |
| FP40•63 | - | 06 | S8 | - | L | OF/OD | / |
| Front pump | | | | | | | |
| 40•63 | - | | L | OF/OD | / | | |
| Intermediate pump | | | | | | | |
| 40•63 | - | | L | OF/OD | - | S | - |
| | | | | | | 0 | N |
| Rear pump | | | | | | | |

| 1 | Pump type | Code |
|---|---|------------------|
| | 3.75 (61,43) in ³ /rev (cm ³ /rev) | FP 40•63 |
| | 4.43 (72,60) in ³ /rev (cm ³ /rev) | FP 40•73 |
| | 5.28 (86,56) in ³ /rev (cm ³ /rev) | FP 40•87 |
| | 6.64 (108,90) in ³ /rev (cm ³ /rev) | FP 40•109 |
| | 8.18 (134,03) in ³ /rev (cm ³ /rev) | FP 40•133 |
| | 9.20 (150,79) in ³ /rev (cm ³ /rev) | FP 40•151 |

| 2 | Drive shaft | Code |
|---|---------------------------|-----------|
| | SAE "C" spline (14 teeth) | 06 |
| | SAE "C" straigh | 34 |

| 3 | mounting flange | Code |
|---|-------------------|-----------|
| | SAE "C" 2-4 holes | S8 |

| 4 | Ports position | Code |
|---|----------------|----------|
| | Side | L |

| Code | Ports IN/OUT | 5 |
|--|--------------|---|
| SAE STRAIGHT THREAD PORTS (ODT) | | |
| Side | Pump type | |
| OF/OD | FP 40•63 | |
| OF/OD | FP 40•73 | |
| OG/OF | FP 40•87 | |
| OG/OF | FP 40•109 | |
| OH/OF | FP 40•133 | |
| OH/OF | FP 40•151 | |

| Code | Rotation | 6 |
|----------|----------|---|
| S | Left | |
| D | Right | |

| Code | Version | 7 |
|----------|--|---|
| 0 | Without outboard bearing | |
| 1 | With outboard bearing | |
| 2 | With outboard bearing and indep. shaft | |

| Code | Seals (a) | 8 |
|-------------|---------------------------------|---|
| N | Buna N (standard) | |
| V | Viton | |
| N Bz | Buna N and Bronze thrust plates | |
| V Bz | Viton and Bronze thrust plates | |

a) Choose the seals according to the temperature shown on page 3

01/08.2005

ORDER EXAMPLE

Triple pump

FP40•63-06S8-LOF/OD/ 40•63-LOF/OD/40•63-LOF/OD S-0-N

PORTS CONNECTORS TIGHTENING TORQUE

 Tightening torque for low pressure side port.



 Tightening torque for high pressure side port [values obtained at 350 bar (5075 psi)]

For reversible rotation, please consult only the tightening torque for high pressure side port.

Replaces: 01/08.2005



GAS STRAIGHT THREAD PORTS

BSPP

| CODE |  | |  | |
|---------------|---|-----------|---|-------------|
| | Nm | (lbf in) | Nm | (lbf in) |
| GC (◆) | 15 ⁺¹ | 133 ÷ 142 | – | – |
| GD | 20 ⁺¹ | 177 ÷ 186 | 50 ^{+2,5} | 443 ÷ 465 |
| GE | 30 ^{+2,5} | 266 ÷ 288 | 90 ⁺⁵ | 797 ÷ 841 |
| GF | 50 ^{+2,5} | 443 ÷ 465 | 130 ⁺¹⁰ | 1151 ÷ 1239 |
| GG ○ | 70 ⁺⁵ | 620 ÷ 664 | 170 ⁺¹⁵ | 1505 ÷ 1637 |
| GH | 70 ⁺⁵ | 620 ÷ 664 | – | – |

SAE STRAIGHT THREAD PORTS J514

ODT

| CODICE |  | |  | |
|---------------|---|-----------|---|-------------|
| | Nm | (lbf in) | Nm | (lbf in) |
| OA (◆) | 15 ⁺¹ | 133 ÷ 142 | – | – |
| OB | 20 ⁺¹ | 177 ÷ 186 | 45 ^{+2,5} | 398 ÷ 420 |
| OD | 40 ^{+2,5} | 354 ÷ 376 | 120 ⁺¹⁰ | 1062 ÷ 1151 |
| OE | 50 ^{+2,5} | 443 ÷ 465 | 145 ⁺¹⁰ | 1283 ÷ 1372 |
| OF | 60 ⁺⁵ | 531 ÷ 575 | 170 ⁺¹⁰ | 1505 ÷ 1593 |
| OG | 70 ⁺⁵ | 620 ÷ 664 | – | – |
| OH | 100 ⁺⁵ | 885 ÷ 929 | – | – |

(◆) Drain port: FORMULA 30 and FORMULA 40 rear drain (R).

○ 03/05.2013

BEARING SUPPORT FOR COUPLING TO ZF P.T.O.(ISO Standard)

SL9 - SR9

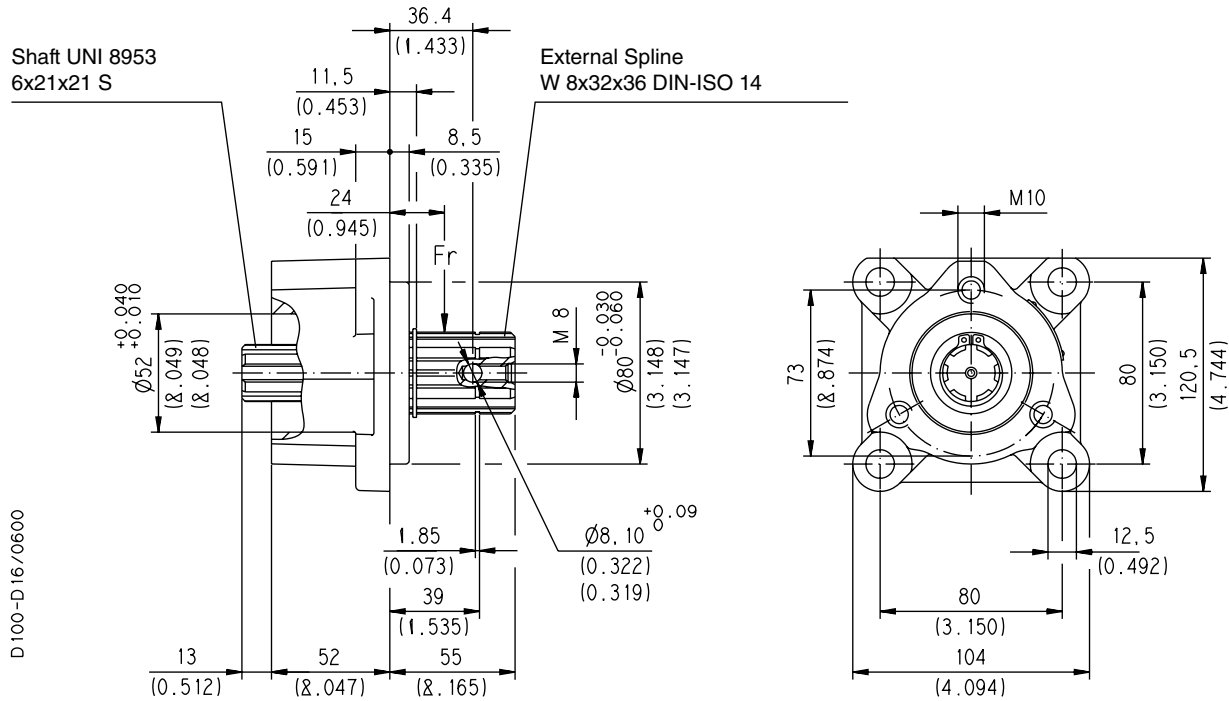



The bearing support allows FORMULA Italian standard pumps to be coupled to P.T.O. of commercial vehicles.

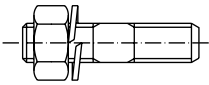

| Ordering code | Max. radial load 24 mm (0.945 in) from mounting face (Fr) | Mass |
|---------------|---|------------|
| | N | kg (lbs) |
| SL9 | — | 2,7 (5.95) |
| SR9 | Low load | |

01/08.2005

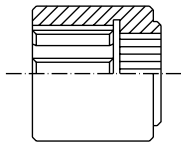
KIT to assemble FP20 - 13 T1 and FP30 - 13 T pumps with support

| Part | Q.ty | Description | Ordering code |
|---|------|---|-------------------|
|  | 3 | Stud M 10x30 UNI 5911 Nut M 10 Washer 10 DIN 7980 | |
|  | 1 | Gasket | KIT 10 - A |
|  | 1 | Splined coupling MA 6x21x25 UNI 8953 - A 22x19 DIN 5482 L= 31 | |

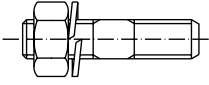
KIT to assemble FP30 - 19 T and FP40 - 19 T pumps with support

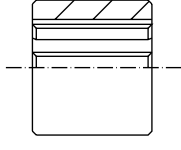
| Part | Q.ty | Description | Ordering code |
|---|------|---|-------------------|
|  | 3 | Stud M 10x30 UNI 5911 Nut M 10 UNI 7473 | |
|  | 1 | Gasket | KIT 17 - A |
|  | 1 | Splined coupling MA 6x21x25 UNI 8953 L= 31 | |

01/08.2005

APPLICATIONS FOR FORMULA PUMPS WITH ZF P.T.O.(ISO STANDARD)

D100-108/1003

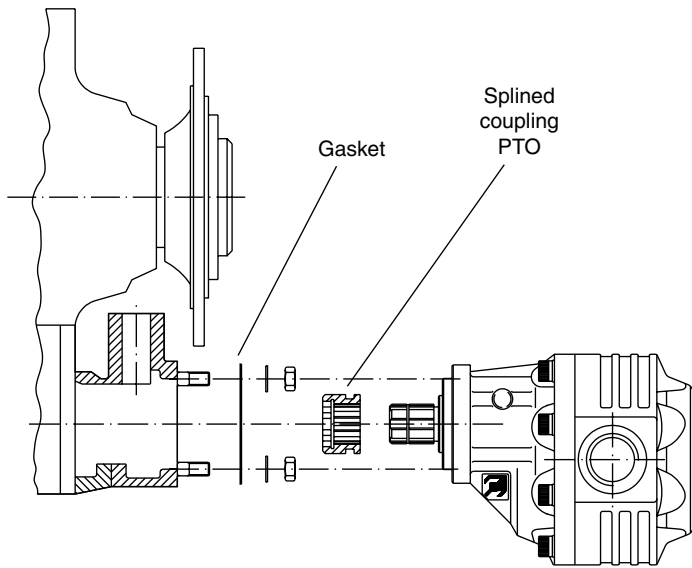

The FORMULA pumps in the application with radial load can be directly connected to the “ZF” P.T.O.

D100-D85/0493

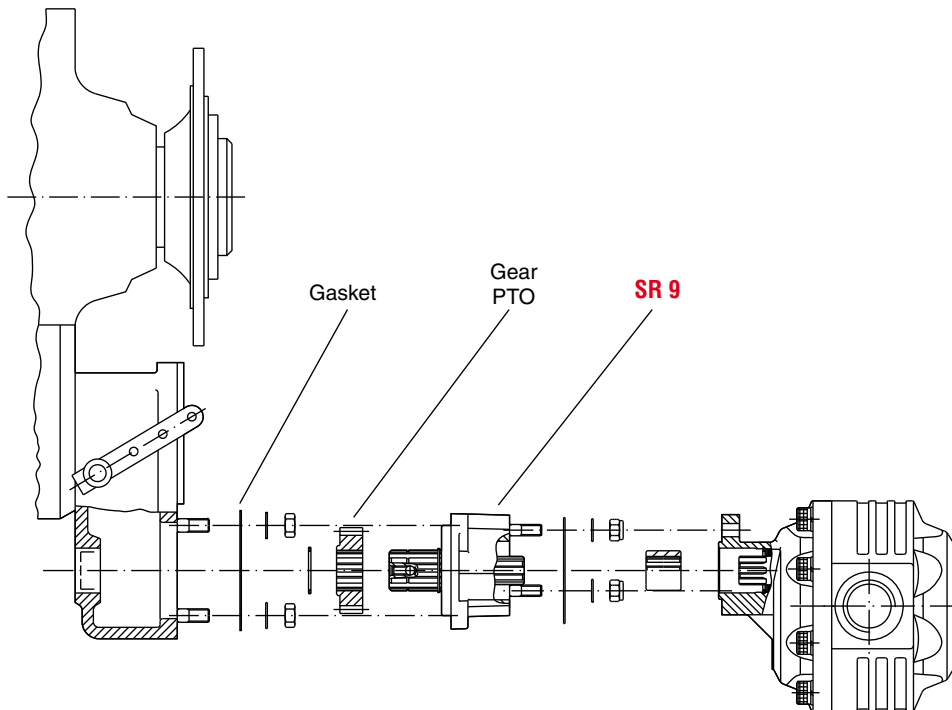

The FORMULA pumps in the application with radial load can be directly connected to the “ZF” P.T.O. with straight teeth gear using the SR9 support.

01/08.2005

APPLICATIONS FOR FORMULA PUMPS WITH ZF P.T.O.(ISO STANDARD)

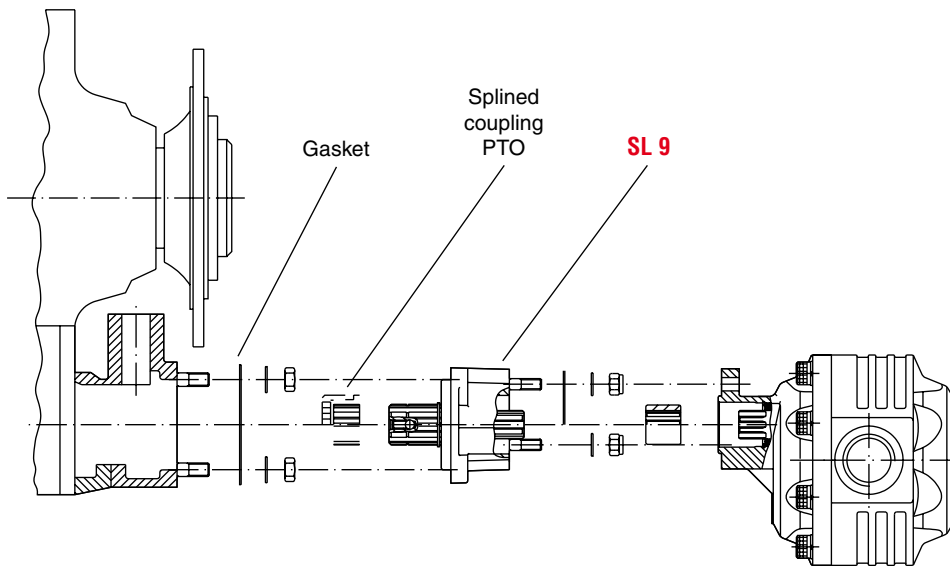

The FORMULA pumps in the application without radial load can be directly connected to the “ZF” P.T.O. only on self sealed version using the SL9 support.

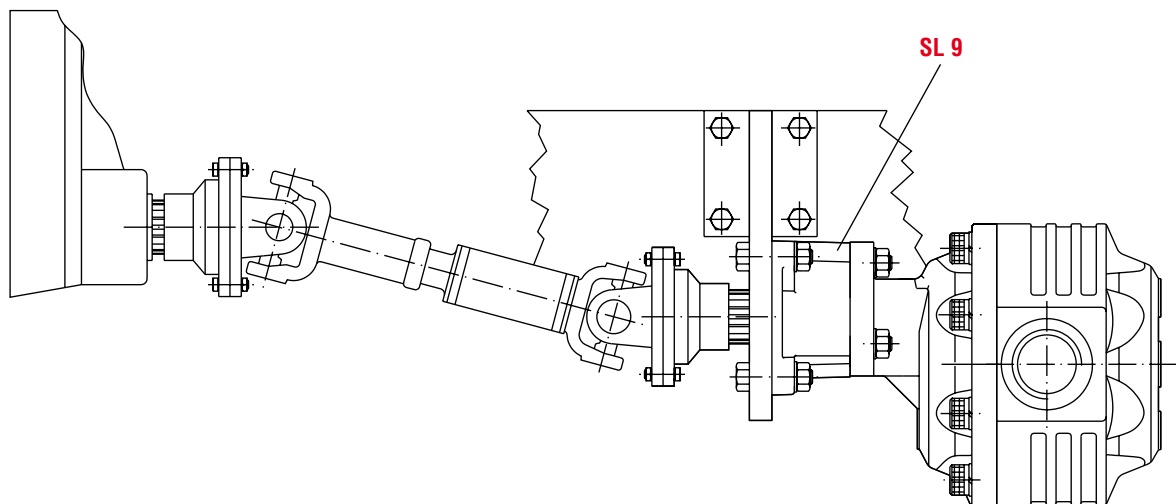

01/08.2005

D100-D86/0493

Use SL9 support to apply the universal joint.

CHANGING ROTATION

Example of changing rotation: from FP30 pump counterclockwise to clockwise

To change rotation of unidirectional pumps is necessary to operate in the following way:

1. Clean the pump externally with care.
2. Loosen, and remove, the clamp bolts (1)
3. Coat the sharp edges of the drive shaft (4) with adhesive tape and smear a layer of clean grease on the shaft end extension to avoid damaging the lip of the shaft seal when removing the mounting flange.
4. Remove the mounting flange (2), taking care to keep the flange as straight as possible during removal. If the flange is stuck, tap around the edge with a fibre or rubber mallet in order to break away from the body. Ensure that while removing the front mounting flange, the drive shaft and other components remain position.
5. Ease the drive gear (4) up to facilitate removal the front plate (3), taking care that the precision ground surfaces do not become damaged, and remove the drive gear.
6. Remove the driven gear (5) without overturning. The rear plate has not to be removed.
7. Re-locate the driven gear (5) in the position previously occupied by the drive gear (4)
8. Re-locate the drive gear (4) in the position previously occupied by the driven gear (5)
9. Replace the front plate (3) in its original position.
10. Remove the grub screw (6) from the mounting flange (2) and re-locate it in the other threaded hole in the same flange.
11. Gently wipe the machined surface of the mounting flange (2) and the body with a flat hand stone.
12. Refit the front mounting flange (2) turned 180° from its original position.
13. Refit the clamp bolts (1) with the washers and tighten in a crisscross pattern to a torque value of 70 ± 7 Nm ($558 \div 682$ lbf in).
14. Check that the pump rotates freely when the drive shaft (4) is turned by hand. If not a pressure plate seal may be pinched.
15. The pump is ready for installation with the original rotation reversed.

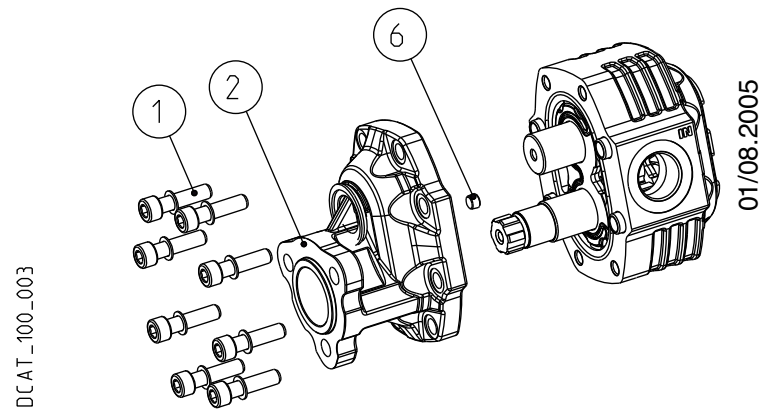
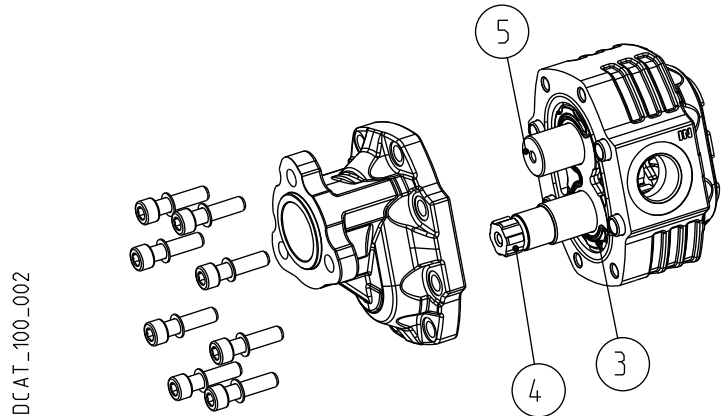
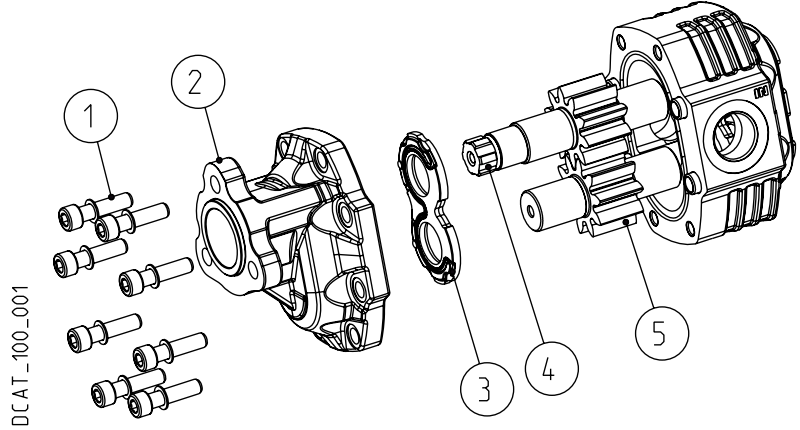

INSTRUCTIONS

INSTALLATION

The direction of rotation of single-rotation pumps must be the same as that of the drive shaft. Check that the coupling flange correctly aligns the transmission shaft and the pump shaft, the connection do not generate an axial or radial load on the pump shaft

TANK

Tank capacity must be sufficient for the system's operating conditions (~ 3 times the amount of oil in circulation) to avoid overheating of the fluid. A heat exchanger should be installed if necessary. The intake and return lines in the tank must be spaced apart (by inserting a vertical divider) to prevent the return-line oil from being taken up again immediately.

LINES

The lines must have a major diameter which is at least as large as the diameter of pump ports, and must be perfectly sealed. To reduce loss of power, the lines should be as short as possible, reducing the sources of hydraulic resistance (elbow, throttling, gate valves, etc.) to a minimum. A length of flexible tubing is recommended to reduce the transmission of vibrations. All return lines must end below the minimum oil level, to prevent foaming. Before connecting the lines, remove any plugs and make sure that the lines are perfectly clean

FILTERS

We recommend filtering the entire system flow. Filters on suction and return line must be fitted in according to the contamination class as indicated in the first pages of the catalogue. Casappa recommends to use its own production filters:

HYDRAULIC FLUID

Use hydraulic fluid conforming to the table as specified in the first pages of the catalogue. Avoid using mixtures of different oils which could result in decomposition and reduction of the oil's lubricating power.

STARTING UP

Check that all circuit connections are tight and that the entire system is completely clean. Insert the oil in the tank, using a filter. Bleed the circuit to assist in filling. Set the pressure relief valves to the lowest possible setting. Turn on the system for a few moments at minimum speed, then bleed the circuit again and check the level of oil in the tank. Then gradually increase the pressure and speed of rotation until the pre-set operating levels as specified in the catalogue are attained.

PERIODICAL CHECKS - MAINTENANCE

Keep the outside surface clean especially in the area of the drive shaft seal. In fact, abrasive powder can accelerate wear on the seal and cause leakage. Replace filters regularly to keep the fluid clean. The oil level must be checked and oil replaced periodically depending on the system's operating conditions.

01/08.2005



Our policy is one of continuous improvement in product. Specification of items may, therefore, be changed without notice.

F 03 T A

Edition: 03/05.2013

Replaces: F 02 T A



Headquarters:

CASAPPA S.p.A.

Via Balestrieri, 1

43044 Lemignano di Collecchio

Parma (Italy)

Tel. (+39) 0521 30 41 11

Fax (+39) 0521 80 46 00

IP Videoconferencing

E-mail: info@casappa.com

www.casappa.com

